

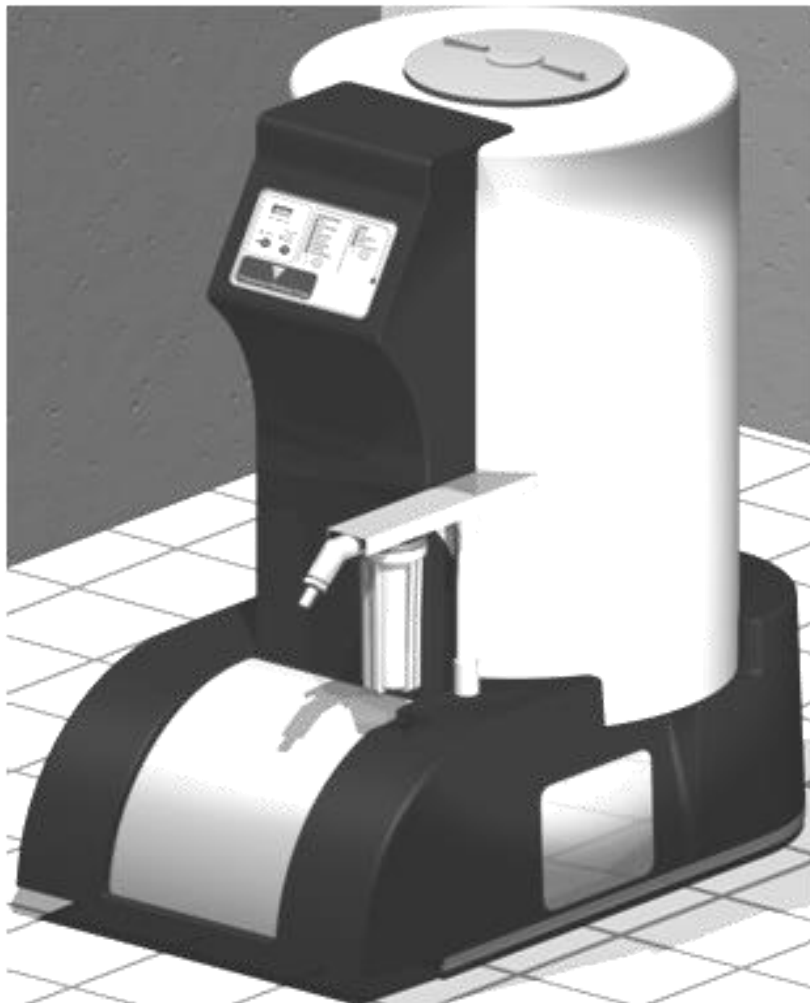

**FRESENIUS
MEDICAL CARE**

**DRY ACID
DISSOLUTION UNIT
99 GALLONS (375 LITERS)**



TECHNICIAN'S MANUAL

P/N 460031 Rev. A

Fresenius Medical Care Dry Acid Dissolution Unit: 99 Gallons (375 Liters) Technician's Manual

© Copyright 2016, Fresenius Medical Care North America– All Rights Reserved.

This document contains proprietary and confidential information from Fresenius USA, Inc. The contents of this manual may not be disclosed to third parties, copied, or duplicated in any form, in whole or in part, without the prior written permission of Fresenius USA, Inc.

Fresenius Medical Care, the triangle logo and GranuFlo® are trademarks of Fresenius Medical Care Holdings, Inc. or its affiliated companies. Citrasate® DRY is a trademark of Advanced Renal Technologies and is used under license from Advanced Renal Technologies. All other trademarks are the property of their respective owners.

Caution: US Federal Law restricts this device to sale by or on the order of a physician.

Indications for Use: The Fresenius Medical Care Dry Acid Dissolution Unit mixes Fresenius Medical Care distributed dry acid concentrate products with hemodialysis quality water. The resulting liquid acid concentrates are intended for use in three-stream hemodialysis machines calibrated for acid and bicarbonate concentrates.

As part of the Conditions for Coverage, it is the Medical Director's responsibility that the Operators of the Fresenius Medical Care Dry Acid Dissolution Unit must be trained in its operation and thoroughly familiar with the contents of this manual. Operators must be proficient and able to distinguish between normal and abnormal operation.

Assembly, installation, adjustment, or repair is to be performed only by persons authorized by the facility Medical Director or by Fresenius USA, Inc. Fresenius Medical Care Concentrate Dry Acid Dissolution Unit spare parts manual, P/N 460009, Field Service Bulletins, and other documentation are located on the Internet at <http://www.fmcna.com>.

Only Original Equipment Manufacturer (*OEM*) Fresenius Medical Care parts should be used in the repair or upgrade of the Fresenius Medical Care Dry Acid Dissolution Unit. Although, parts may look similar to parts in various vendor catalogs or brick and mortar stores the Dry Acid Dissolution Unit uses parts that have been specified and tested in accordance to *ANSI/AAMI/ISO* guidelines. The use of non-*OEM* parts will void your warranty and may cause patient harm.

For further information regarding the operation, repair, parts, or maintenance of the Fresenius Medical Care Dry Acid Dissolution Unit, please contact:

Fresenius USA, Inc.
4040 Nelson Avenue.
Concord, CA 94520.

(800) 227-2572

TABLE OF CONTENTS

I	WARNINGS AND CAUTIONS
II	HYDRAULIC DESCRIPTION
III	ELECTRONIC CIRCUIT DESCRIPTION
IV	MAINTENANCE
V	TROUBLESHOOTING

ADDITIONAL DOCUMENTATION*

99 Dry Acid Wiring Diagram (P/N 260107)

*The latest revision of the additional documentation can be found at the following web location:

<http://www.freseniusmedicalcare.us/en/home/healthcare-professionals/renal-products/dialysis/product-support-documentation/>



SECTION I - WARNINGS AND CAUTIONS

READ ALL INSTRUCTIONS BEFORE USE!

For your safety, the information in this manual must be followed to minimize the risk of electrical shock, prevent property damage, personal injury, or loss of life. There are many important safety messages in this manual and on your Dry Acid Dissolution Unit. The following table lists symbols and the criteria of their descriptions, which is used throughout this manual. Your safety and the safety of others are very important. Always read and abide by all safety messages

The Fresenius Medical Care 99 Gallon Dry Acid Dissolution Unit is designed and manufactured in accordance to the requirements of Systems for Mixing Concentrate at a Dialysis Facility listed in Section 5.3 of the *ANSI/AAMI RD61:2006* and Section 5.4 of *ISO 13958:2009* Regulations.

Proper training and demonstrated user competency must be completed and documented before a designated operator can be authorized to use the Fresenius Medical Care Dry Acid Dissolution Unit to make Fresenius Medical Care Dry Acid Concentrate.

SYMBOL	DESCRIPTION
	WARNING! A WARNING IS A STATEMENT THAT IDENTIFIES CONDITIONS OR ACTIONS THAT COULD RESULT IN PERSONAL INJURY OR LOSS OF LIFE. WARNINGS FOUND IN THIS MANUAL OUTSIDE OF THIS SECTION ARE DESIGNATED WITH THE WARNING SYMBOL.
	CAUTION: A CAUTION IS A STATEMENT THAT IDENTIFIES CONDITIONS OR ACTIONS THAT COULD RESULT IN DAMAGE TO THE MACHINE
	NOTE: NOTES ARE ADVISORY COMMENTS OR RECOMMENDATIONS REGARDING PRACTICES OR PROCEDURES.
BUTTON	A BUTTON IS A PRESSURE-SENSITIVE, RAISED PAD FOUND ON THE CONTROL PANEL THAT IS USED TO INITIATE AN ACTION OR OPERATION.



WARNING! NEVER PUT YOUR HEAD INTO THE DRY ACID DISSOLUTION UNIT TANK. THIS MAY RESULT IN OPERATOR FALLING INTO TANK.



WARNING! IN THE EVENT OF A FOREIGN OBJECT FALLING INTO THE TANK DURING ANY ACTIVE OPERATION, THE OPERATION SHOULD BE PAUSED. IF NEEDED, USE STEP MODE TO PLACE UNIT INTO A DRAIN OPERATION TO EMPTY THE TANK. IF CONCENTRATE SOLUTION NEEDS TO BE DISPOSED, MAKE SURE TO COMPLY WITH LOCAL, STATE AND FEDERAL REQUIREMENTS. AFTER DRAIN OPERATION, UNPLUG DRY ACID DISSOLUTION UNIT FROM ITS POWER SOURCE. A REACH TOOL IS RECOMMENDED FOR REMOVING FOREIGN OBJECT OUT OF TANK. HOWEVER, SHOULD THE FOREIGN OBJECT BE UNATTAINABLE, CALL TECHNICAL SERVICE FOR FURTHER ASSISTANCE (1-800-227-2572).



WARNING! IF THE DRY ACID DISSOLUTION UNIT IS RELOCATED A SAMPLE MUST BE DRAWN FROM THE FIRST BATCH OF CONCENTRATE MADE, WHICH MUST BE ANALYZED FOR CORRECT SOLUTION MIX BEFORE THE CONCENTRATE CAN BE USED. PRIOR TO RELOCATION, REQUEST TWO (2) EMPTY SAMPLE BOTTLES (P/N G83-535-02) THEN CALL TECHNICAL SERVICE FOR FURTHER ASSISTANCE (1-800-227-2572).



WARNING! THE USE OF EYE PROTECTION, DUST MASK AND GLOVES IS RECOMMENDED WHEN HANDLING DRY ACID PRODUCT. IF CONTACT WITH EYES, RINSE IMMEDIATELY FOR 15 MINUTES. IF CONTACT WITH SKIN, FLUSH WITH PLENTY OF SOAP AND WATER. SEE MATERIAL SAFETY DATA SHEETS (MSDS) FOR THE DRY ACID PRODUCT BEING USED FOR FURTHER PERSONAL PROTECTIVE EQUIPMENT (PPE) OR EMERGENCY REQUIREMENTS/INSTRUCTIONS.



WARNING! SHOULD THE DRY ACID DISSOLUTION UNIT FAIL TO COMPLETE ANY OPERATION WITHIN ANY CYCLE DO NOT PROCEED THROUGH CYCLE USING STEP MODE. CALL TECHNICAL SERVICE FOR FURTHER ASSISTANCE (1-800-227-2572).



WARNING! FAILURES TO INSTALL, OPERATE, AND MAINTAIN THIS EQUIPMENT ACCORDING TO THE MANUFACTURER'S INSTRUCTIONS MAY CAUSE PATIENT DEATH OR INJURY.



WARNING! THIS DRY ACID DISSOLUTION UNIT MAY BE SUSCEPTIBLE TO ELECTROMAGNETIC INTERFERENCE (EMI). DEVICES EMITTING ELECTROMAGNETIC RADIATION SUCH AS ANALOG PORTABLE PHONES, RADIO EQUIPMENT (WALKIE-TALKIES, ETC.), RADIO TRANSMITTERS, AND LIKE EQUIPMENT, SHOULD NOT BE USED IN THE VICINITY OF THIS EQUIPMENT. THE OPERATOR SHOULD MONITOR THE FUNCTION OF THE MACHINE AND REMOVE UNNECESSARY EQUIPMENT FROM THE TREATMENT AREA SHOULD THESE EVENTS OCCURS.



WARNING! THE ELECTRICAL SOURCE MUST BE SINGLE PHASE, THREE-CONDUCTOR TYPE PROVIDED WITH A GROUND FAULT INTERRUPTER AT 120 VAC, 60 HZ. THE PROPER POLARITY AND GROUND INTEGRITY MUST BE INITIALLY CHECKED AND MAINTAINED. FAILURE TO DO SO MAY RESULT IN ELECTRICAL SHOCK OR BURN TO THE OPERATOR.



WARNING! SHOCK HAZARD. DO NOT REMOVE PANELS. REFER SERVICING TO QUALIFIED PERSONNEL. REPLACE FUSES ONLY WITH THE SAME TYPE AND RATING.



WARNING! FOLLOWING DISINFECTION, TWO (2) COMPLETE RINSE CYCLES MUST BE PERFORMED AND THE UNIT TESTED TO ENSURE THE ABSENCE OF RESIDUAL BLEACH [REFER TO SECTION 4.3 BLEACH DISINFECTION, PAGE IV-2].



WARNING! USE THE SUPPLIED *HYDROMETER* TO MEASURE THE SPECIFIC GRAVITY OF A SAMPLE OF THE MIXED FRESenius MEDICAL CARE DRY ACID PRODUCT [SEE DRY ACID DISSOLUTION UNIT 99 GALLONS (375 LITERS) OPERATOR'S MANUAL P/N 460017].



WARNING! CONNECT WATER INLET ACCORDING TO THE SPECIFICATIONS FOR THE DRY ACID DISSOLUTION UNIT. THE WATER USED MUST MEET *ANSI/AAMI* OR *ISO* STANDARDS FOR WATER USED IN HEMODIALYSIS (CURRENTLY *ANSI/AMMI RD62*, OR *ISO 13959*). THE CORRECT IONIC CONCENTRATION AND BACTERIAL QUALITY CAN GENERALLY BE ACHIEVED IN THE DIALYSATE ONLY WITH TREATED WATER. BE SURE THAT ALL SPECIFICATIONS ARE SATISFIED. THE WATER SOURCE MUST BE MONITORED PERIODICALLY TO DETECT FLUCTUATIONS IN WATER COMPOSITION AND QUALITY THAT COULD HAVE AN ADVERSE EFFECT ON THE PATIENT, HEMODIALYSIS MACHINE OR DRY ACID DISSOLUTION UNIT. PARTICULAR ATTENTION MUST BE TAKEN FOR CHEMICALS SUCH AS ALUMINUM, CHLORINE, AND CHLORAMINES, AS THESE CHEMICALS CAN CAUSE COMPLICATIONS IN DIALYSIS PATIENTS. THE CHEMICAL QUALITY OF THE TREATED WATER USED FOR DIALYSIS SHOULD BE ANALYZED A LEAST ONCE A YEAR TO ENSURE IT MEETS THE REQUIREMENTS OF *ANSI/AMMI RD62*, OR *ISO 13959*.



WARNING! THE DIALYSIS PHYSICIAN IS RESPONSIBLE FOR SELECTING THE APPROPRIATE CONCENTRATE MIXING EQUIPMENT FOR DIALYSIS AND THE PRESCRIPTION FOR DIALYSIS.



WARNING! THE DRY ACID DISSOLUTION UNIT IS COMPUTER CONTROLLED. EXTREME CARE SHOULD BE EXERCISED IN ITS OPERATION. WHEN POWER IS CONNECTED TO THE DRY ACID DISSOLUTION UNIT, A FAILURE OF THE COMPUTER COULD START ANY OF THE OPERATIONS AT ANY TIME.



CAUTION! ASSEMBLY, INSTALLATION, ADJUSTMENT, OR REPAIR IS TO BE PERFORMED ONLY BY PERSONS AUTHORIZED BY THE FACILITY MEDICAL DIRECTOR OR BY FRESenius MEDICAL CARE.



WARNING! DISINFECT DRY ACID DISSOLUTION UNIT TANK IF WATER IN TANK UNIT EXCEEDS 200 CFU/ML AS OUTLINED BY ANSI/AAMI RD62, OR ISO 13959 [REFER TO SECTION 4.3: BLEACH DISINFECTION, PAGE IV-2].



CAUTION! THE DRY ACID DISSOLUTION UNIT IS ONLY INTENDED FOR MIXING FRESenius MEDICAL CARE DISTRIBUTED DRY ACID CONCENTRATE. DO NOT MIX BICARBONATE IN THE DRY ACID DISSOLUTION UNIT UNLESS A BATCH OF CONCENTRATE SOLUTION REQUIRES NEUTRALIZATION FOR PROPER DISPOSAL. CONCENTRATE SOLUTION MUST BE DISPOSED OF IN ACCORDANCE WITH LOCAL, STATE, AND FEDERAL REQUIREMENTS. SEE DRY ACID DISSOLUTION UNIT 99 GALLONS (375 LITERS) OPERATOR'S MANUAL P/N 460017 FOR THE PROCEDURE TO NEUTRALIZE CONCENTRATE FOR DISPOSAL.



WARNING! AN ANSI/AAMI OR ISO STANDARD PURIFIED WATER ANALYSIS FOR BACTERIA AND ENDOTOXIN IS RECOMMENDED MONTHLY.



WARNING! A BACK PRESSURE REGULATOR MAY BE REQUIRED ON THE TREATED WATER FEED LINE IF THE DRY ACID DISSOLUTION UNIT IS TO BE USED AT THE SAME TIME AS OTHER DIALYSIS EQUIPMENT. THE MAXIMUM INPUT WATER PRESSURE IS 60 PSI AT A MINIMUM FLOW RATE OF ½ GALLON PER MINUTE FOR THE DRY ACID DISSOLUTION UNIT.



WARNING! KEEP THE DRY ACID DISSOLUTION UNIT MIXING AREA FREE OF CLUTTER. THE FLOOR NEAR THE UNIT SHOULD BE KEPT FREE OF WATER TO AVOID SLIP-AND-FALL INJURIES.



NOTE: SOME FACILITIES MAY BE REQUIRED TO PURCHASE AND INSTALL A STORAGE TANK FOR CENTRALIZED ACID FEED LOOPS. IF SO, THE STORAGE TANK AND ASSOCIATED PLUMBING INTERCONNECTIONS MUST BE COMPLETED PRIOR TO THE INSTALLATION OF THE DRY ACID DISSOLUTION UNIT.



NOTE: THE PUMP IS NOT SELF-PRIMING AND IS INSTALLED WITH A POSITIVE FLOODED SUCTION. THE LIQUID BEING PUMPED SERVES AS THE LUBRICATION FOR THE IMPELLER ASSEMBLY SPINNING ON A POLYPROPYLENE STATIONARY SHAFT. IF THE PUMP IS RUN DRY FOR LONGER THAN 30 SECONDS THIS MAY CAUSE IMPELLER DAMAGE.



NOTE: CONCENTRATE SOLUTION MUST BE DISPOSED OF IN ACCORDANCE WITH LOCAL, STATE, AND FEDERAL REQUIREMENTS. IF YOU HAVE QUESTIONS REGARDING THE DISPOSAL OF CONCENTRATE SOLUTION, THEN SEE THE DRY ACID DISSOLUTION UNIT 99 GALLONS (375 LITERS) OPERATOR'S MANUAL P/N 460017.

SECTION II - HYDRAULIC DESCRIPTION

	Page
HYDRAULIC FLOW DIAGRAM.....	II-2
COMPONENT LOCATION	II-3
COMPONENT DESCRIPTION.....	II-5
COMPONENT STATE TABLES	
DISSOLUTION CYCLE.....	II-10
RINSE CYCLE.....	II-11
RINSE CYCLE.....	II-12
FILL MODE	II-13
RECIRCULATE MODE – SPRAYBALL.....	II-14
RECIRCULATE MODE – JETS.....	II-15
DRAIN MODE.....	II-16
CYCLE COMPLETE MODE.....	II-17
DISSOLUTION CYCLE	II-18
PRE-RINSE FILL.....	II-20
PRE-RINSE SPRAYBALL FLOW.....	II-21
PRE-RINSE JET FLOW.....	II-22
PRE RINSE DRAIN	II-23
DISSOLUTION FILL.....	II-24
ADD GRANULES MODE.....	II-25
MIX MODE.....	II-26
DEAERATION MODE.....	II-27
FINAL FILL MODE.....	II-28
HOMOGENIZE MODE	II-29
TRANSFER MODE	II-30
CYCLE COMPLETE MODE.....	II-31

HYDRAULIC FLOW DIAGRAM

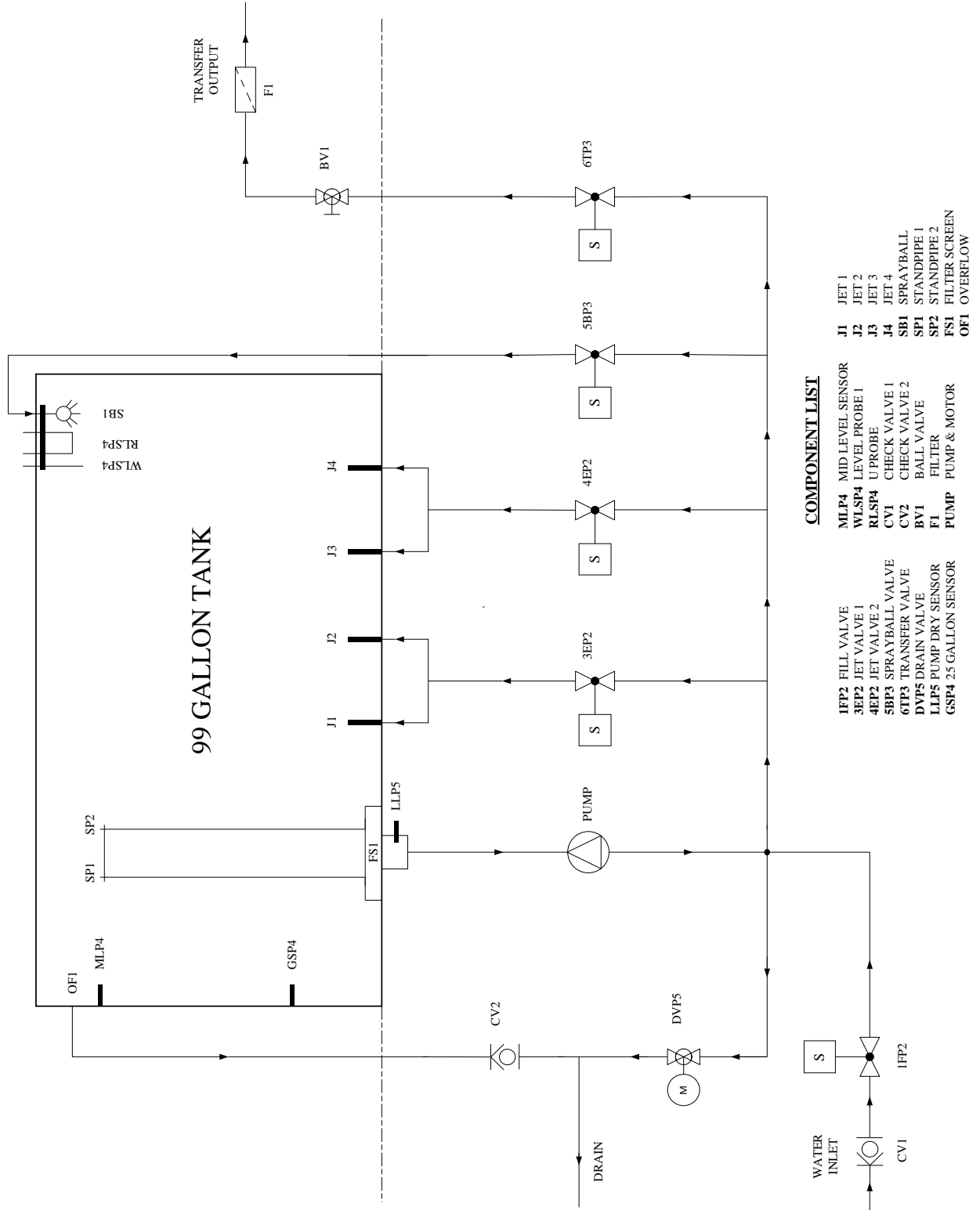

COMPONENT LOCATION

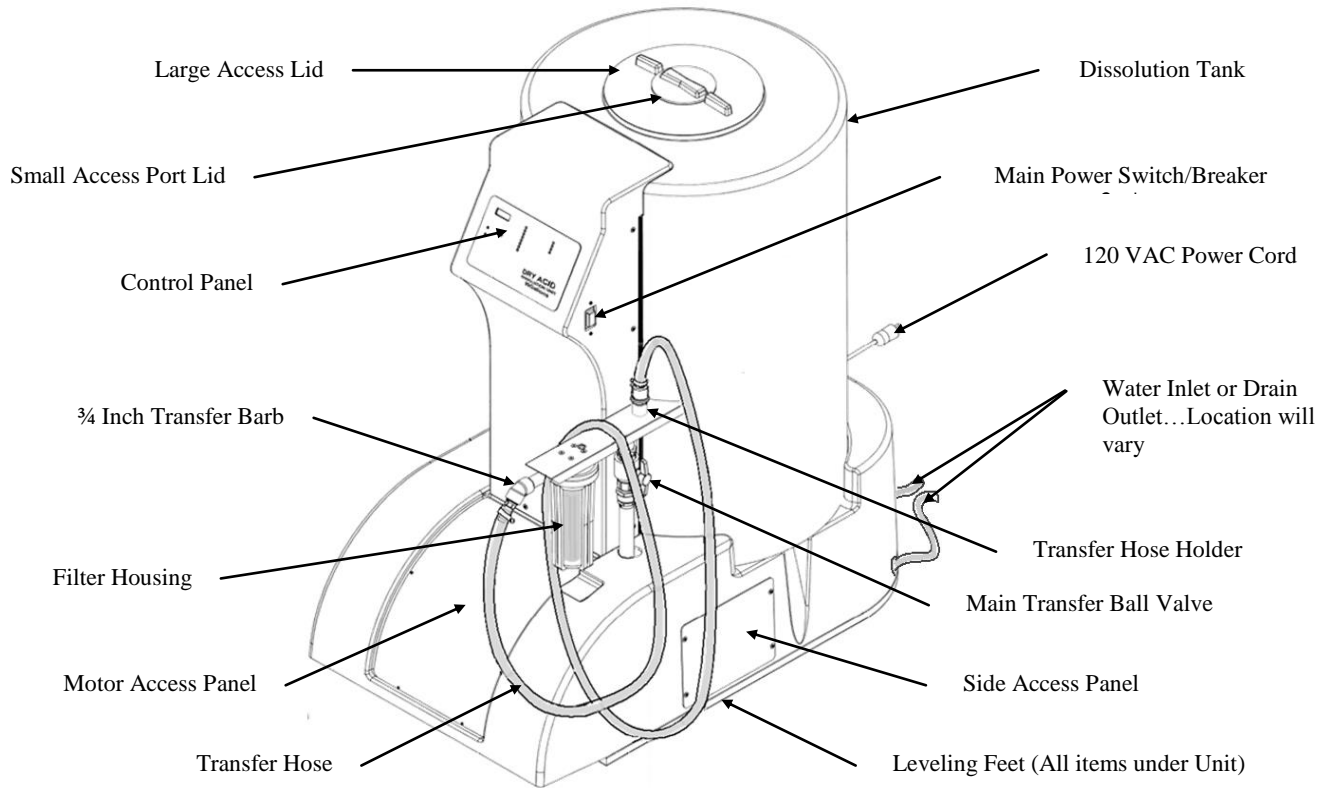

External Parts

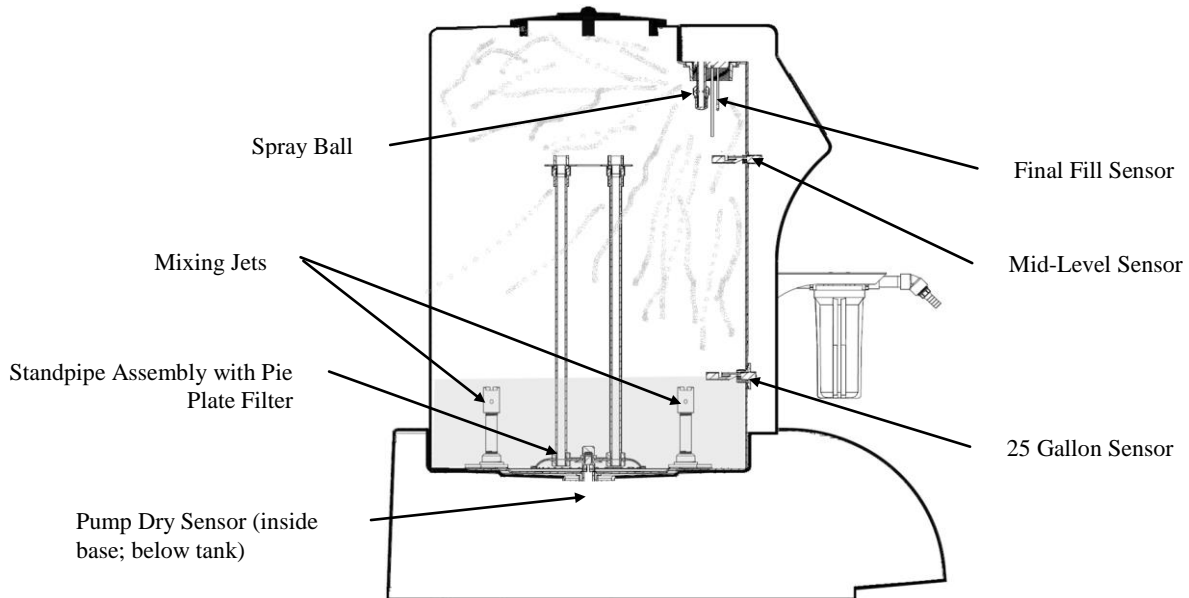

Internal Parts

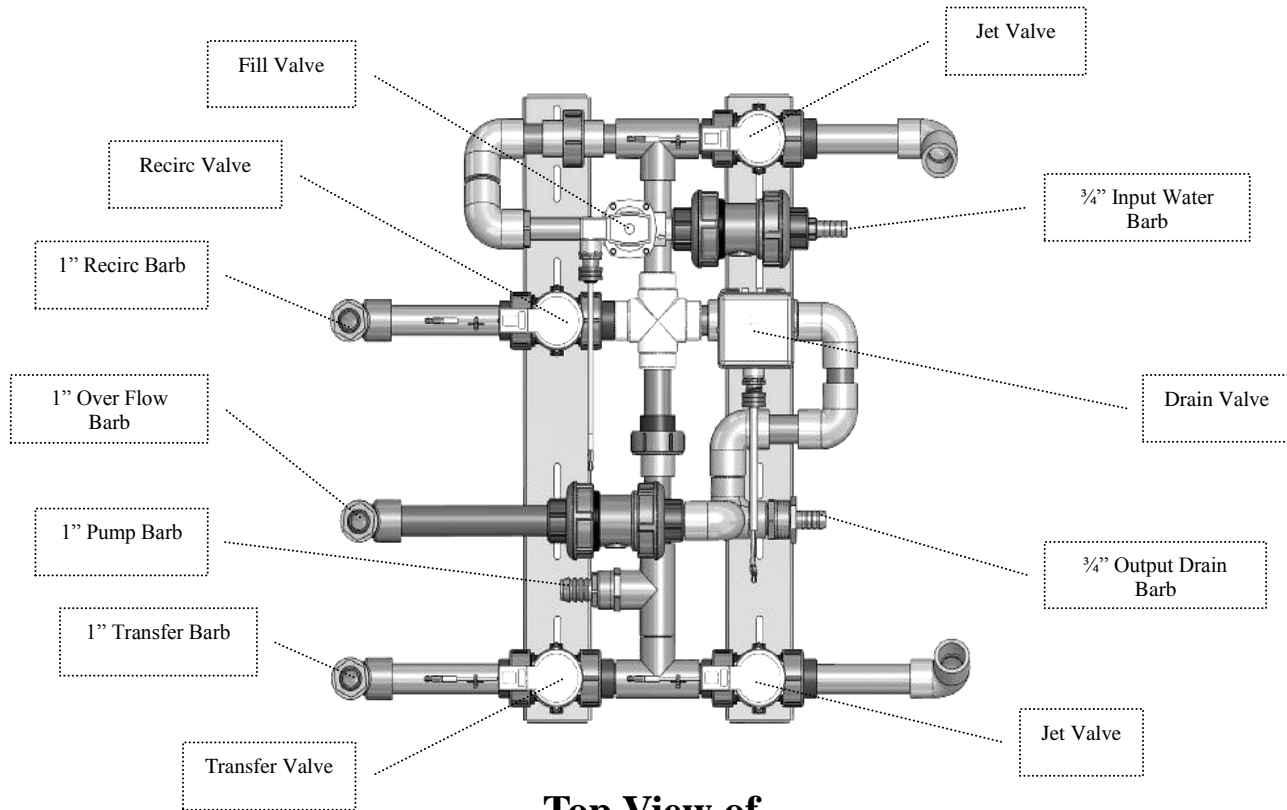

**Top View of
Valve Assembly**

COMPONENT DESCRIPTION

1) Dissolution Tank

The 99 gallon (375 liter) vessel in which the dry acid concentrate is mixed. The mixed concentrate can be transferred to a storage tank or individual containers.

2) Fill Valve



The 24 VDC Fill Valve permits treated water to fill the Dissolution Tank to the required level (25 gallon, mid or final fill levels) in both Dissolution and Rinse Cycles.

3) Jet Valve



There are two 24 VDC Jet Valves located in the hydraulics. They control fluid to the Jets inside the Dissolution Tank. They are active in various Dissolution and Rinse Cycle modes.

4) Recirc Valve



The 24 VDC Recirc Valve opens to allow fluid through the Spray Ball. This is active in RECIRCULATION Mode.

5) Transfer Valve



The 24 VDC Transfer Valve directs flow from the effluent of the Pump to the Transfer Hose. This is active in TRANSFER Mode.

6) Drain Valve



The 24 VDC Drain Valve allows the contents of the Dissolution Tank to go to the drain. The Drain Valve operates in both cycles.

Dissolution Cycle – Drain Valve will open in CYCLE COMPLETE.

Rinse Cycle – Drain Valve will open in both DRAIN Mode, and in CYCLE COMPLETE.

7) Pump Dry Sensor



This 12 VDC sensor is located at the base of the Dissolution Tank. Used during TRANSFER Mode and DRAIN Mode to turn off the Pump when the Dissolution Tank is empty.

When replacing this sensor, replace the complete Pump Dry Sensor Assembly.

8) 25 Gallon Sensor

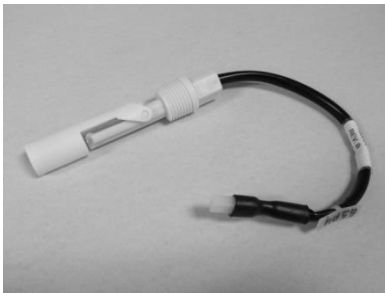

This 12 VDC sensor is the lower of the two float switches on the side of the Dissolution Tank. When the Dissolution Tank is empty, the float switch is in the down (open) position.

When fluid reaches the sensor, it will lift up (close) the float switch. This sensor allows the Dissolution Tank to fill with approximately 25 gallons of water. It is active in the Rinse Cycle and during the pre-rinse in the Dissolution Cycle.

9) Mid-Level Sensor



This 12 VDC sensor is the higher of the two float switches on the side of the Dissolution Tank. When the Dissolution Tank is empty, the float switch is in the down (open) position.

When fluid reaches the sensor, it will lift up (close) the float switch. In Dissolution Cycle, the Dissolution Tank will fill to this sensor before the ADD GRANULES Mode is initiated.

This sensor is active only during FILL Mode in the Dissolution Cycle.

10) Final Fill Sensor

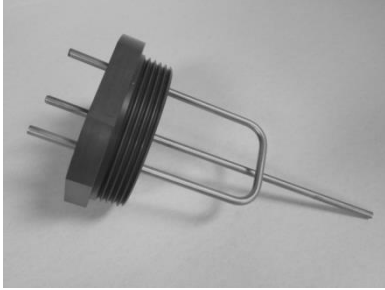

This 12 VDC sensor is mounted on the top of the Dissolution Tank, and is used only during FINAL FILL Mode. When water reaches the Final Fill Sensor it will close the Fill Valve. The Dissolution Tank will have approximately 99 gallons in it. Sensor is only active in the Dissolution Cycle.

11) Check Valve (water supply)



This device is located below the Dissolution Tank platform. It is used to prevent backflow into the incoming treated water.

12) Check Valve (drain)



This device prevents fluid from backing up through the drain into the Dissolution Tank.

13) Main Transfer Ball Valve (Filter Housing)



This ball valve in series with the Filter Housing is used to flush the Transfer Hose or transfer the solution from the Dissolution Tank to a storage tank or individual containers.

14) Filter Housing



This is located on the lower right side of the blue Control Console; it holds a 1 micron filter. The filter is used to remove any packaging particulate matter that may be in the mixed concentrate. Do not allow this filter to stand in fresh water. The filter should only be left completely filled with concentrate.

15) Pump



This 120 VAC pump operates in both cycles.
Dissolution Cycle – The pump operates during the pre-rinse and in ADD GRANULES, MIX, HOMOGENIZE and TRANSFER Modes.
Rinse Cycle – During RECIRCULATION Mode, the pump is used to move water through the Spray Ball and Jets. In DRAIN Mode the Pump is used to move water out to the drain.

16) Jets



There are four Jets located at the bottom of the Dissolution Tank. Water flows through these Jets to fill or mix fluid in the Dissolution Tank. They are utilized in both Dissolution and Rinse Cycles.

17) Spray Ball



The Spray Ball is located in the upper portion of the Dissolution Tank; used in the Dissolution Cycle pre-rinse, and the Rinse Cycle. The Pump will send water through the Recirc Valve, directing fluid to the Spray Ball. As the fluid goes through the Spray Ball, it will rotate, rinsing the inside surface of the Dissolution Tank removing all residual residue.

18) Standpipe Assembly



This assembly is located on the inside center of the Dissolution Tank. It consists of two PVC pipes that are connected to the base filter (pie plate) at the bottom of the Dissolution Tank. This assembly helps to agitate the fluid within the Dissolution Tank during MIX Mode and HOMOGENIZE Mode. A filter is at the base which prevents debris being drawn into the Pump.

19) Overflow Riser

This pipe is connected near the top of the Dissolution Tank and is plumbed directly to drain. In an overflow situation it routes water to the drain and avoids a fluid spill on the floor.

20) Transfer Line Output

This is the hose that connects the output of the Filter Housing assembly to the Transfer Nozzle or storage tank. It is used to transfer liquid from the Dissolution Tank.

21) Transfer Nozzle (Optional)



If this nozzle is used, it will connect to the end of the Transfer Line Output; it allows an individual container to be filled.

COMPONENT STATE TABLE

Dissolution Cycle

Mode	Duration (if timed)	Pump Dry Sensor	25 Gallon Sensor	Mid- Level Sensor	Final Fill Sensor	Start Button	Drain Valve	Fill Valve	Transfer Valve	Recirc Valve	Jet Valve 1 & 2	Pump
Initial State						X	Open					
Fill - Fill to 25 Gallon Sensor			X					Open			Open	
Fill - Recirc	1 min									Open		On
Fill - Recirc	1 min										Open	On
Fill - Drain		X					Open					On
Fill – Fill to Mid-Level Sensor				X				Open			Open	
Add Granules						X					Open	On
Mix	35 min										Open	On
Deaeration	2 min											
Final Fill					X			Open			Open	
Homogenize	10 min										Open	On
Ready to Transfer						X						
Transfer		X							Open			On
Complete						X	Open					

X=Sensor Input Active



Note: The pump will turn off 3 seconds before the end of any mode in which the pump is running to allow for a smooth switching of the valves.

Rinse Cycle

Mode	Duration (if timed)	Pump Dry Sensor	25 Gallon Sensor	Mid- Level Sensor	Final Fill Sensor	Rinse Start Button	Drain Valve	Fill Valve	Transfer Valve	Recirc Valve	Jet Valve 1 & 2	Pump
Initial State						X	Open					
Fill			X					Open			Open	
Recirculate	3 min									Open		On
Recirculate	3 min										Open	On
Recirculate	3 min									Open		On
Recirculate	3 min										Open	On
Drain		X					Open					On
Fill			X					Open			Open	
Recirculate	3 min									Open		On
Recirculate	3 min										Open	On
Recirculate	3 min									Open		On
Recirculate	3 min										Open	On
Drain		X					Open					On
Complete						X	Open					

X=Sensor Input Active

 Note: The pump will turn off 3 seconds before the end of any mode in which the pump is running to allow for a smooth switching of the valves.

RINSE CYCLE

Rinse Cycle consists of four modes: Fill, Recirculate, Drain and Cycle Complete. All valves are Normally Closed (NC). The pump will turn off three seconds before the end of any mode/phase in which it is running to ensure smooth switching of the valves. Rinse Cycle begins by pressing the Rinse Start button.

1. Fill – Fill Valve and Jet Valves 1 and 2 open. Treated water will flow through all four jets inside the tank, through the pump into the bottom of the tank, even though the pump is off. Fill LED is on. It will fill until water reaches the 25 Gallon Sensor, then the Fill Valve and Jet Valves 1 and 2 close. Fill LED will turn off. It will then advance to Recirculate.
2. Recirculate – This mode is 12 minutes, consists of 4 phases: Two sprayball flow and two jet flow. Recirculate LED is on.
 - A. Sprayball Flow (3minutes) –Recirc Valve opens, and the pump turns on; water is recirculated through the sprayball.
 - B. Jet Flow (3 minutes) – Jet valves 1 and 2 open, and the pump turns on; water is recirculated through all 4 jets.
 - C. Sprayball Flow (3 minutes) –Recirc Valve opens, and the pump turns on; water is recirculated through the sprayball.
 - D. Jet Flow (3 minutes) – Jet Valves 1 and 2 open, and the pump turns on; water is recirculated through all 4 jets.

Pump turns off, Jet Valves 1 and 2 close, Recirculate LED turns off, display is cleared, machine advances to Drain mode.
3. Drain – Drain Valve opens and the pump turns on. Drain LED is on. When the Pump Dry Sensor detects that the tank has emptied, the pump will run for an additional ten seconds then turn off.

After the first Rinse Cycle, the machine will do a second Rinse Cycle, i.e. Fill, Recirculate and Drain, then go to Cycle Complete.
4. Cycle Complete – Drain Valve opens – Cycle Complete LED is on.

FILL MODE

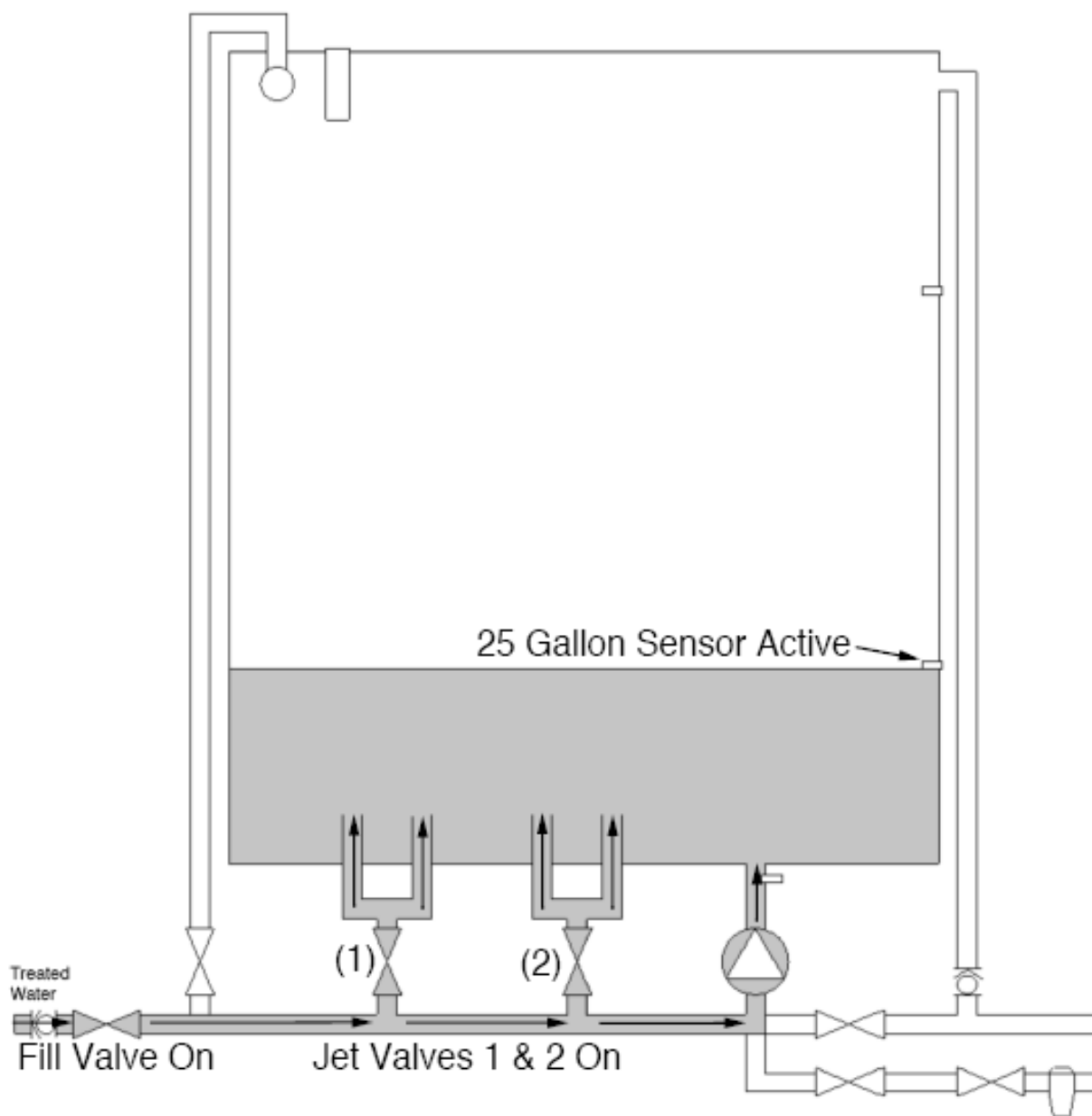

Fill Valve and Jet Valves 1 and 2 open. Treated water will flow through all four jets inside the tank, through the pump into the bottom of the tank, even though the pump is off. It will fill until water reaches the 25 Gallon Sensor.

RECIRCULATE MODE - SPRAYBALL

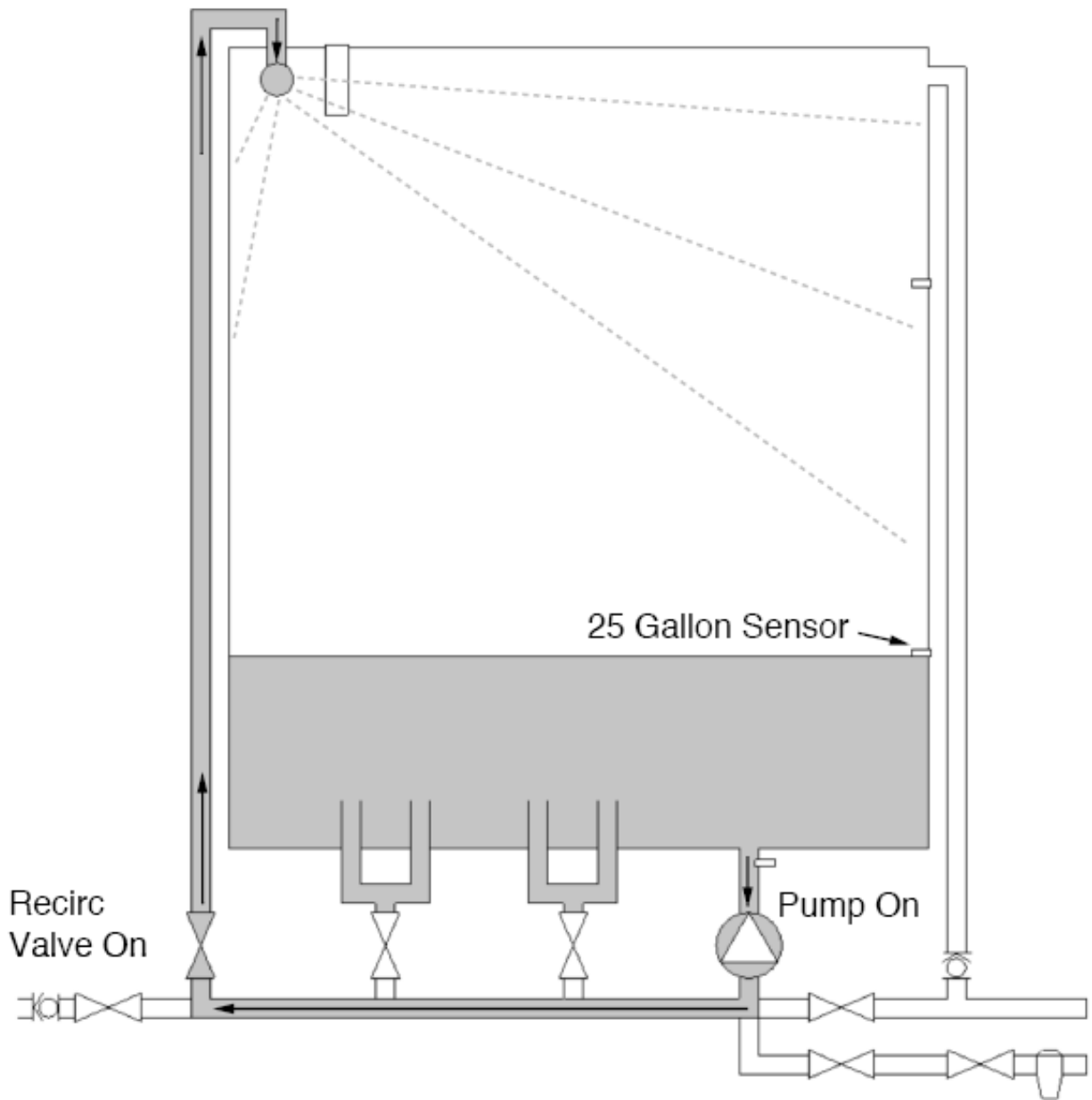

Sprayball Flow (3minutes) – Recirc Valve opens, and the pump turns on; water is recirculated through the sprayball.

RECIRCULATE MODE - JETS

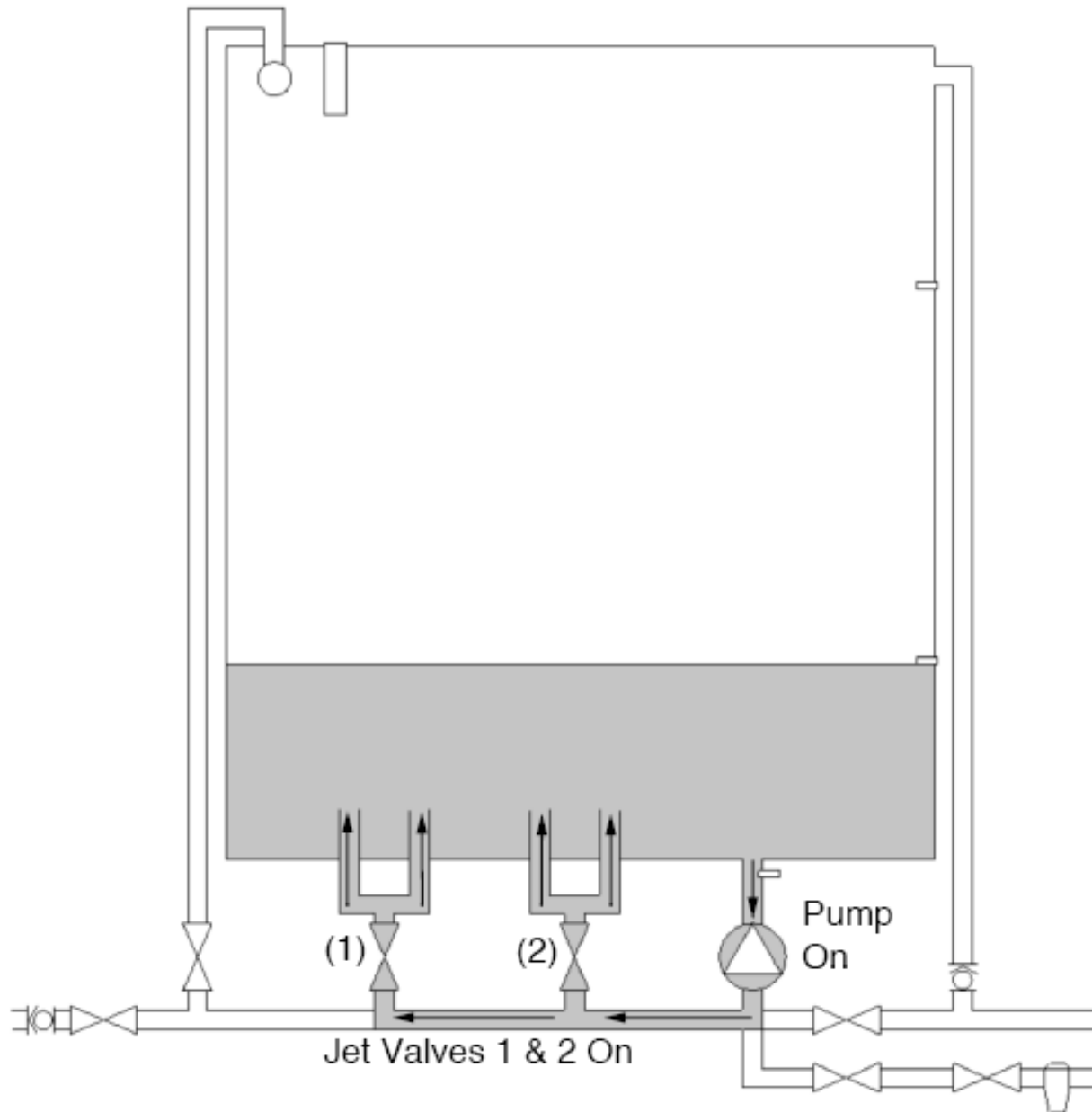

Jet Flow (3 minutes) – Jet Valves 1 and 2 open, and the pump turns on; water is recirculated through all 4 jets.

DRAIN MODE

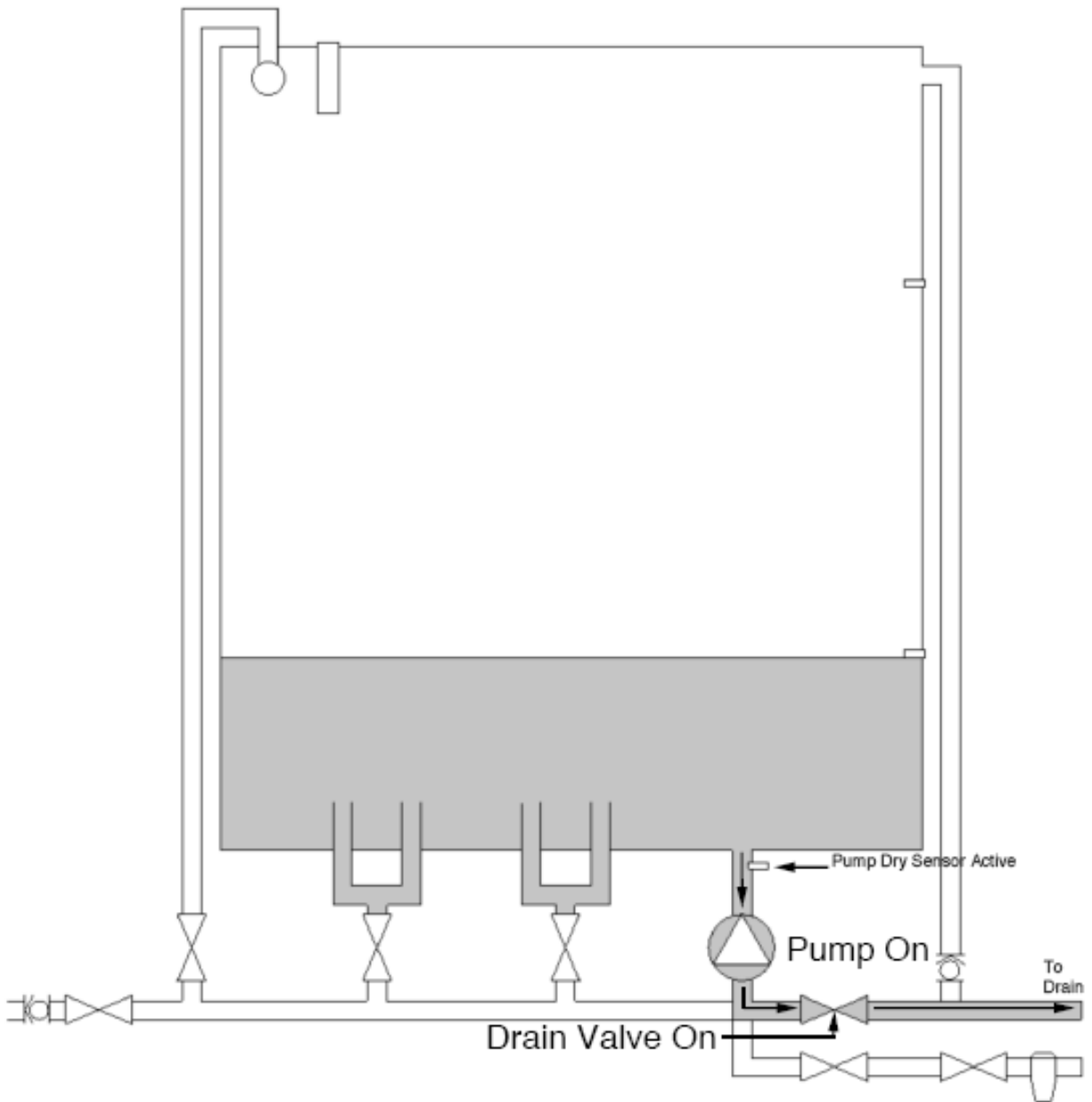

Drain Valve opens and the pump turns on. When the Pump Dry Sensor detects that the tank has emptied, the pump will run for an additional ten seconds then turn off.

CYCLE COMPLETE MODE

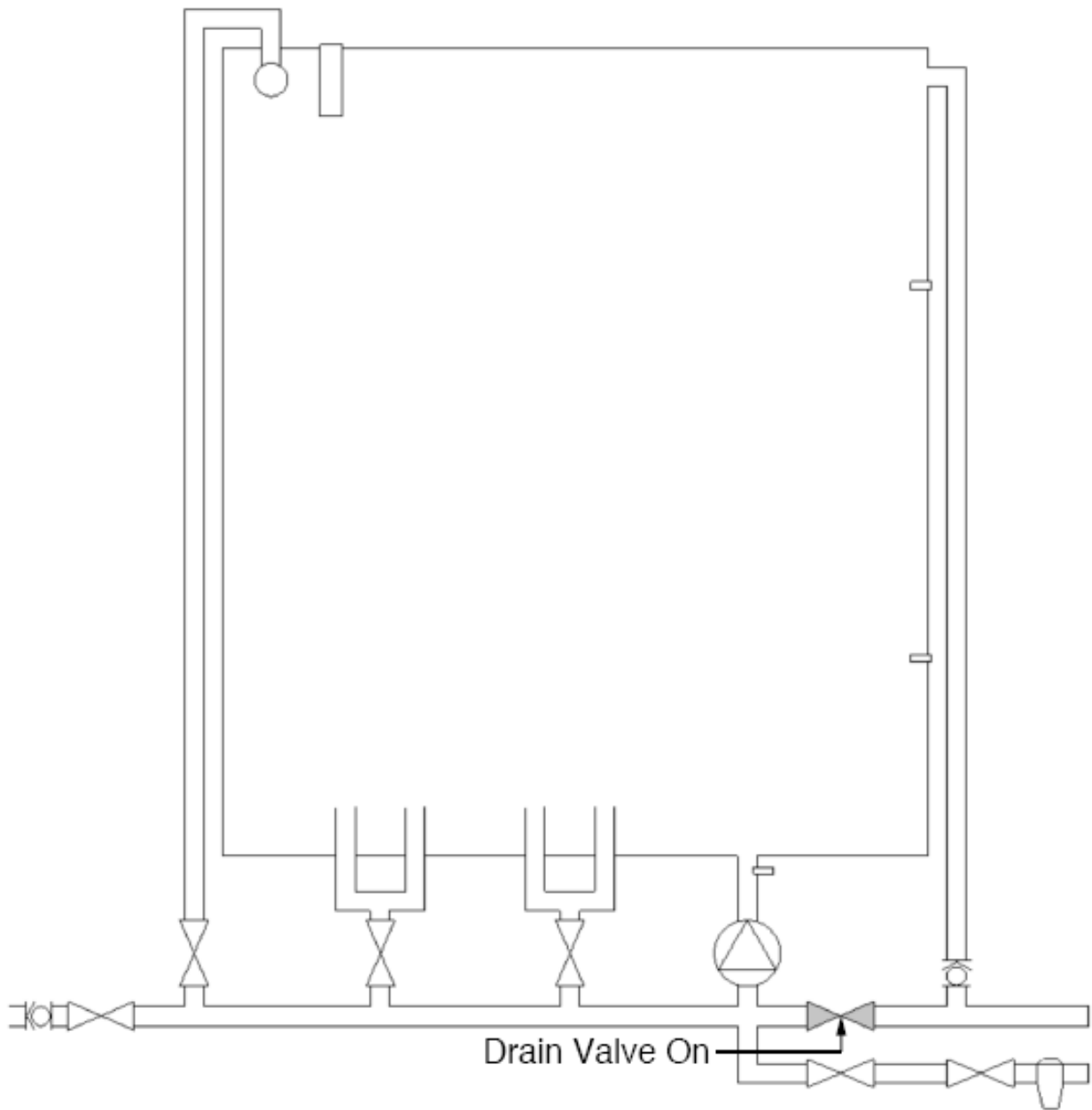

Drain Valve is open.

DISSOLUTION CYCLE

Dissolution Cycle consists of eight modes: Fill, Add Granules, Mix, Deaeration, Final Fill, Homogenize, Transfer and Cycle Complete. The pump will turn off three seconds before the end of any mode/phase in which it is running to ensure smooth switching of the valves. Dissolution Cycle begins by pressing the Dissolution Start button.

1. Fill– Consists of two distinct phases: a.) Pre-rinse, b.)Fill
 - A. Pre-rinse – this is similar to the Rinse Cycle. The times are shorter and it only does it once.
 - I. Pre-Rinse Fill - Fill LED is on. Fill Valve and Jet Valves 1 and 2 open. Treated water will flow through all four jets inside the tank and through the pump into the bottom of the tank, even though the pump is off. Fill LED is on. It will fill until water reaches the 25 Gallon Sensor, then the Fill Valve and Jet Valves 1 and 2 close.
 - II. Pre-Rinse Sprayball Flow (1 minute) –Recirc Valve opens and the pump turn on; water is recirculated through sprayball.
 - III. Pre-Rinse Jet Flow (1 minute) – Jet Valves 1 and 2 open, and the pump turns on; water is recirculated through all 4 jets.
 - IV. Pre-Rinse Drain - Drain Valve opens and the pump turns on. Once the Pump Dry Sensor detects that the tank has emptied, the pump will run for an additional ten seconds then turn off. The drain valve will close and the machine will begin filling.
 - B. Fill – Fill Valve and Jet Valves 1 and 2 open. Treated water will flow through all four jets inside the tank, through the pump into the bottom of the tank, even though the pump is off. Fill LED is on. When treated water reaches the Mid-Level Sensor, the Fill Valve and Jet Valves 1 and 2 close. Fill LED will turn off and machine will advance to Add Granules mode.
2. Add Granules – Jet Valves 1 and 2 open, the pump turns on and Add Granules LED will begin blinking. Concentrate powder can be added at this time. The tank will stay in this mode until the Dissolution Start button is pressed. When Dissolution Start button is pressed it will advance to Mix.
3. Mix –Jet Valves 1 and 2 open and the pump turns on. Mix LED is on. The liquid in the tank recirculates through the four jets. This is a timed 35 minute mode. When the time has elapsed, it will advance to Deaeration.
4. Deaeration – Deaeration LED is on. There is no hydraulic activity. This is a timed two minute cycle. When the time has elapsed, it will advance to Final Fill.

5. Final Fill – Fill Valve and Jet Valves 1 and 2 open. Treated water will flow through all four jets inside the tank and through the pump into the bottom of the tank, even though the pump is off. Final Fill LED is on. When water level in the tank reaches the Final Fill Sensor, Fill Valve and Jet Valves 1 and 2 close. The mixer will advance to Homogenize.
6. Homogenize – Jet Valves 1 and 2 open, and the pump turns on. Homogenize LED is on. The liquid in the tank recirculates through the four jets. This is a timed ten minute mode. At the end of this mode Jet Valves 1 and 2 close and the pump turns off. The mixer advances to Transfer mode.
7. Transfer – Initially transfer LED will blink, no action is happening. Once the Dissolution Start button is pressed, machine will commence transfer. Transfer Valve opens and the pump turns on. Pump Dry Sensor is active, when tank is empty machine will advance to Cycle Complete.
8. Cycle Complete – Drain Valve is open – Cycle Complete LED is on.

DISSOLUTION PRE-RINSE FILL

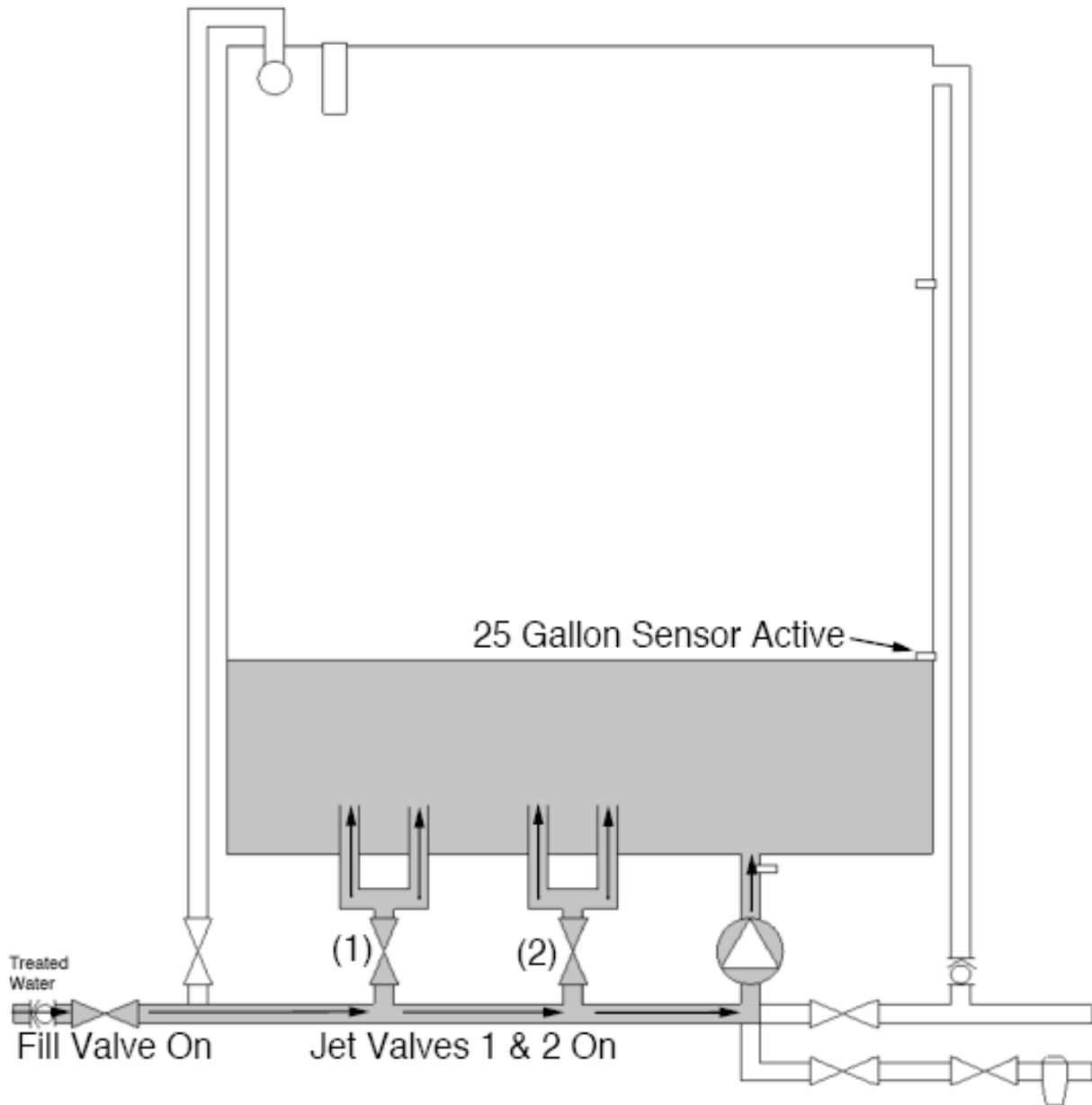

Fill Valve and Jet Valves 1 and 2 open. Treated water will flow through all four jets and through the pump into the bottom of the tank, even though the pump is off.

DISSOLUTION PRE-RINSE SPRAYBALL FLOW

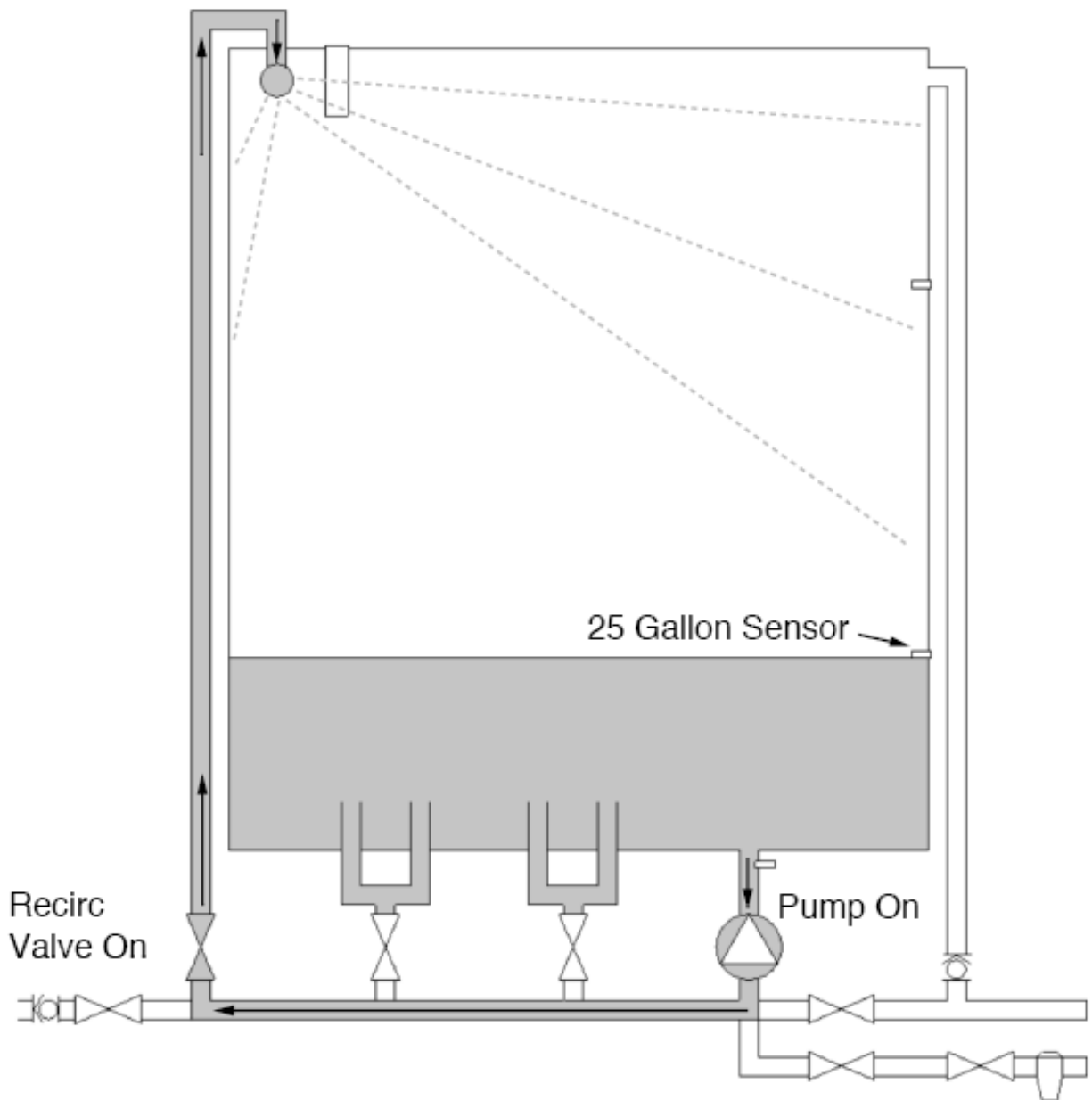

Sprayball Flow (1 minute) –Recirc Valve opens and the pump turn on; water is recirculated through sprayball.

DISSOLUTION PRE-RINSE JET FLOW

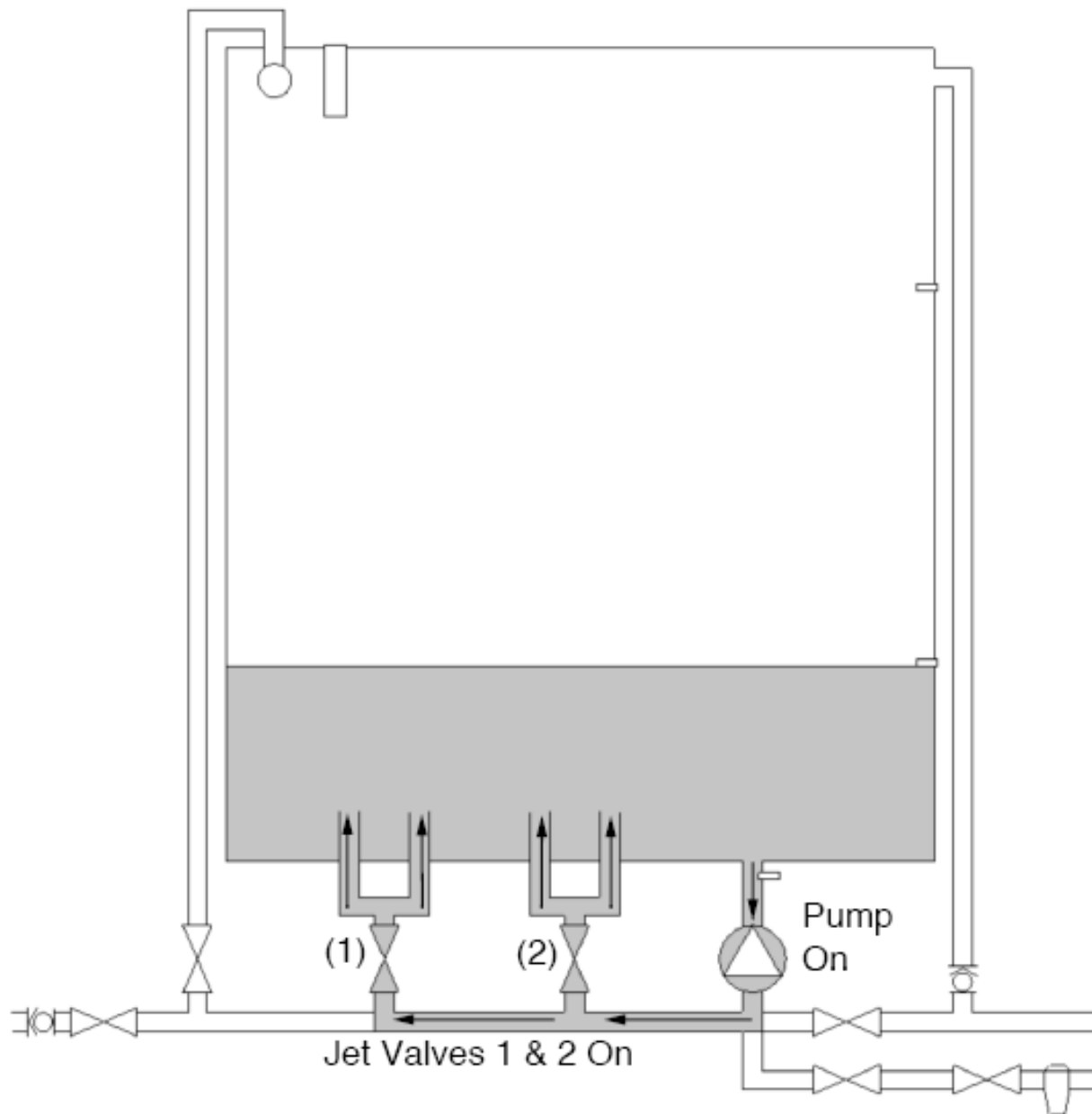

Jet Flow (1 minute) – Jet Valves 1 and 2 open, and the pump turns on; water is recirculated through all 4 jets.

DISSOLUTION PRE-RINSE DRAIN

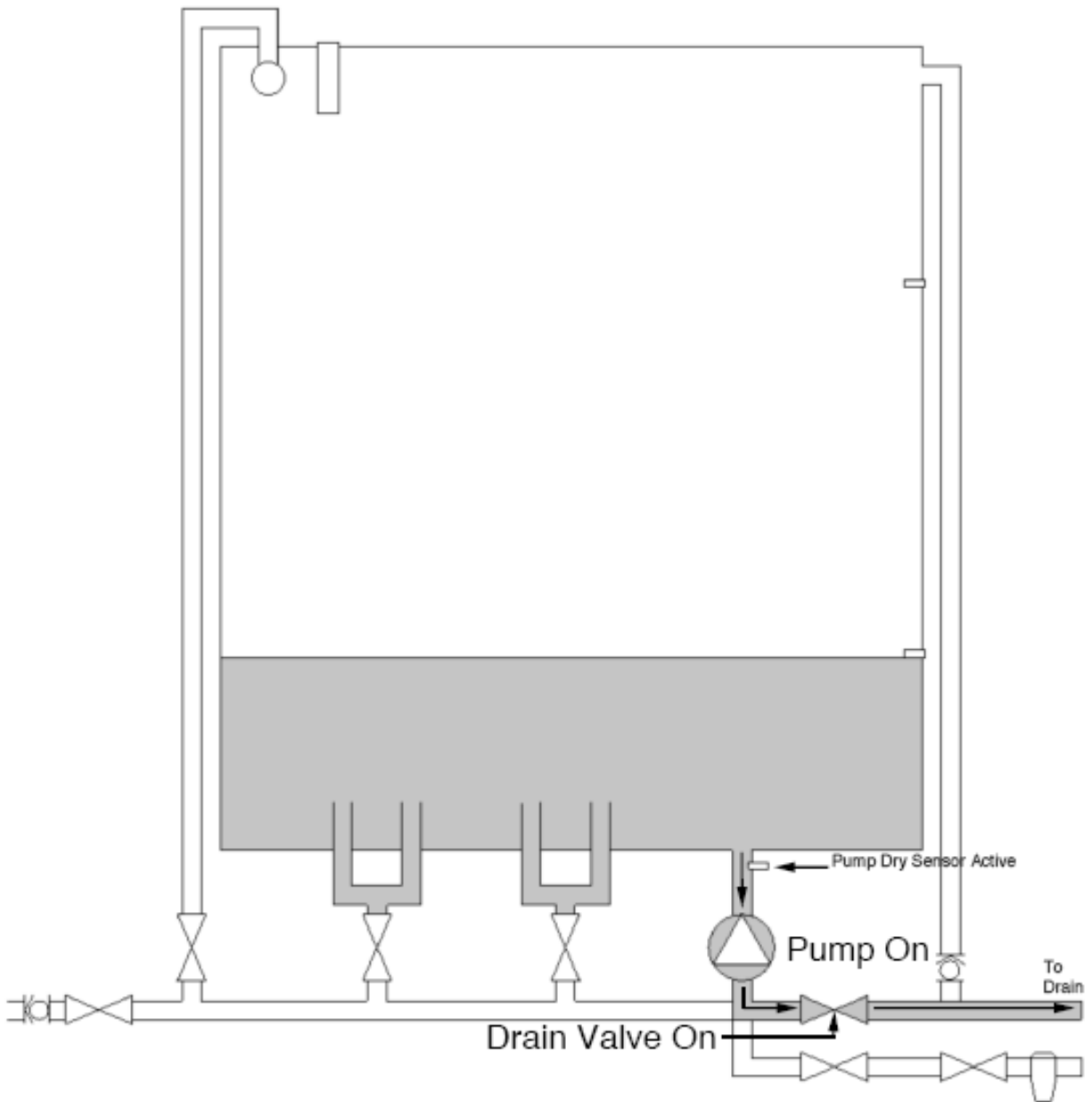

Drain Valve opens and the pump turns on. When the Pump Dry Sensor detects that the tank has emptied, the pump will run for an additional ten seconds then turn off.

DISSOLUTION FILL

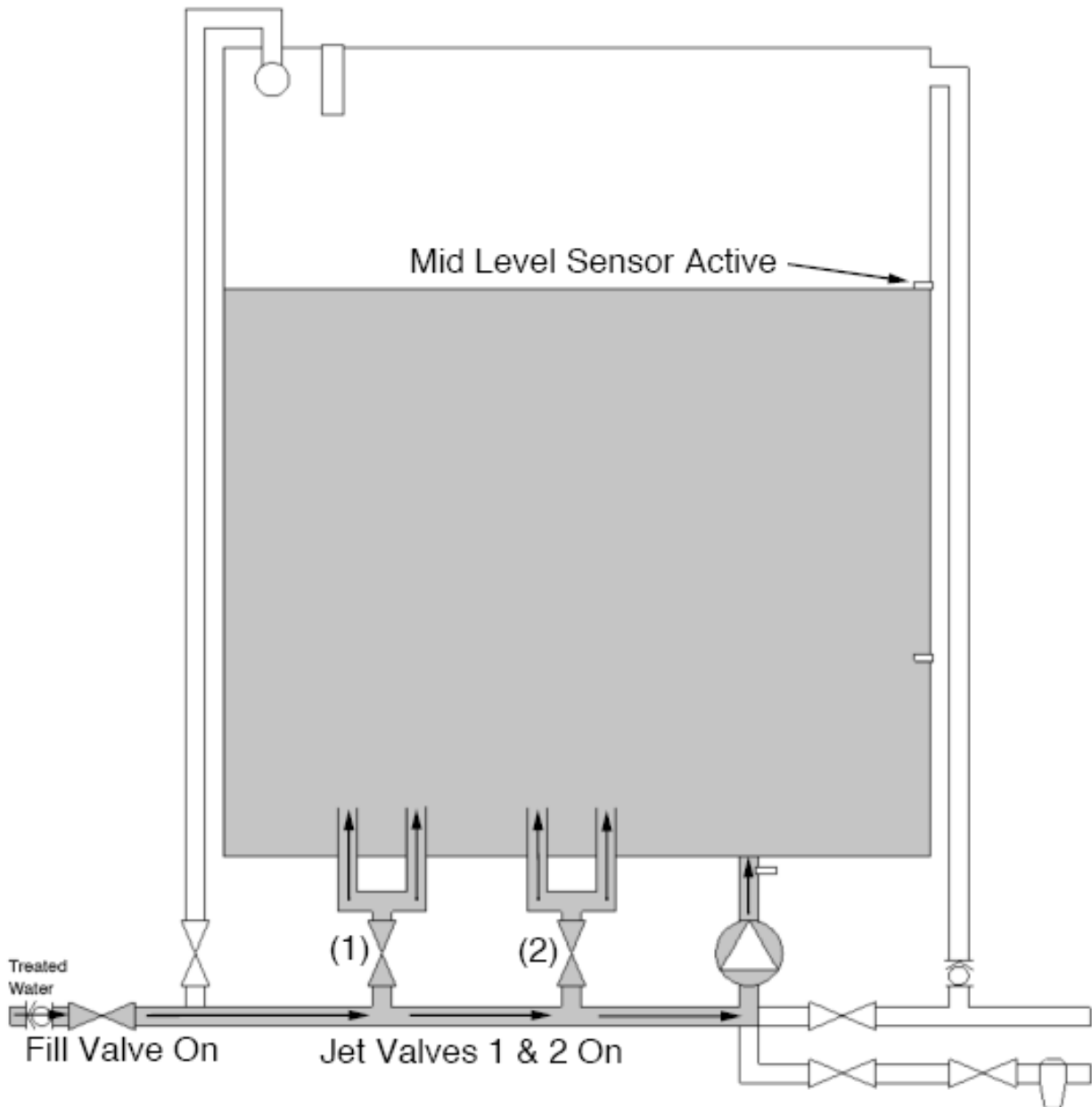

Fill Valve and Jet Valves 1 and 2 open. Treated water will flow through all four jets and through the pump into the bottom of the tank, even though the pump is off.

ADD GRANULES MODE

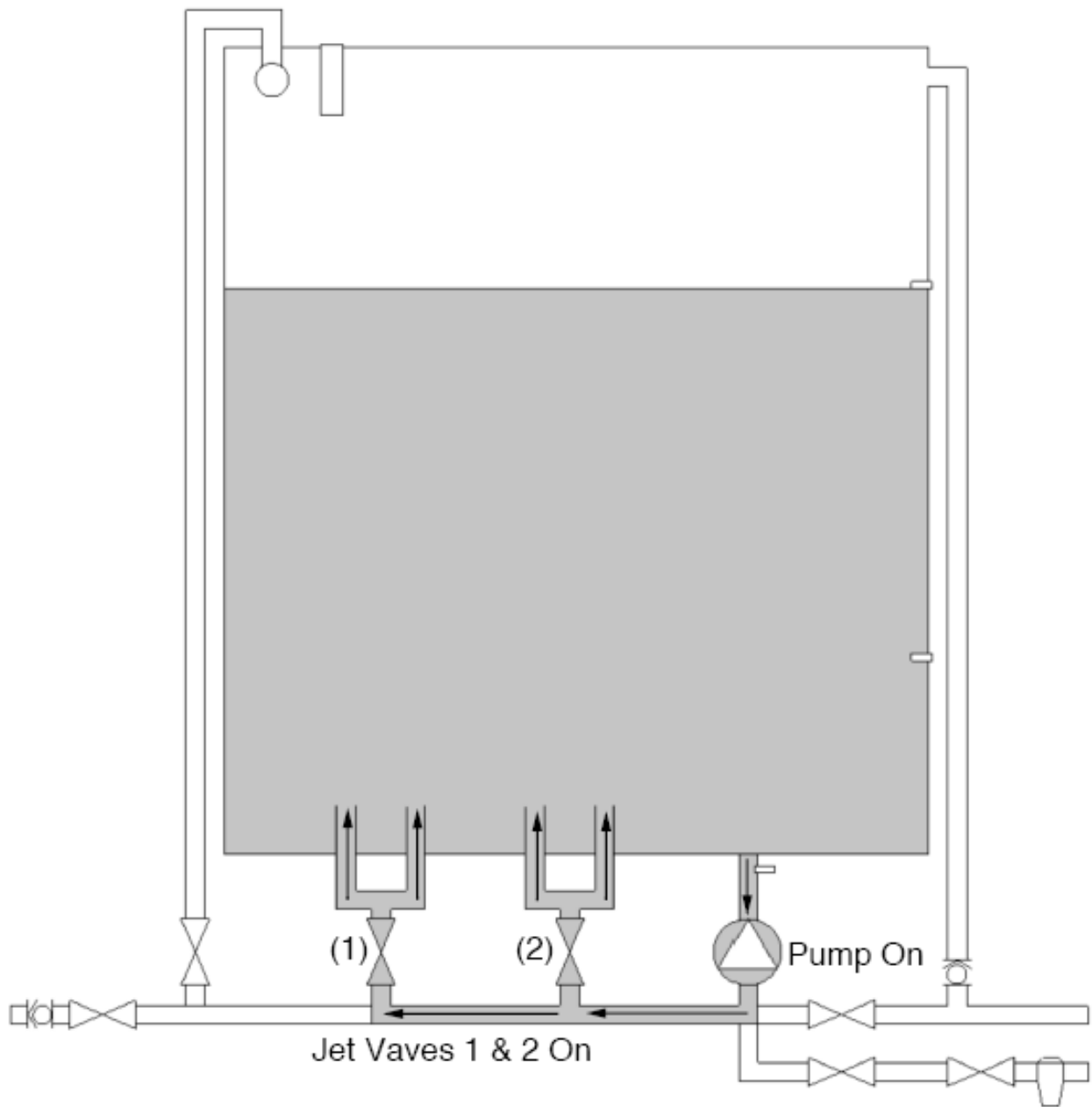

Jet Valves 1 and 2 open, the pump turns on and Add Granules LED will begin blinking. Concentrate powder can be added at this time.

MIX MODE

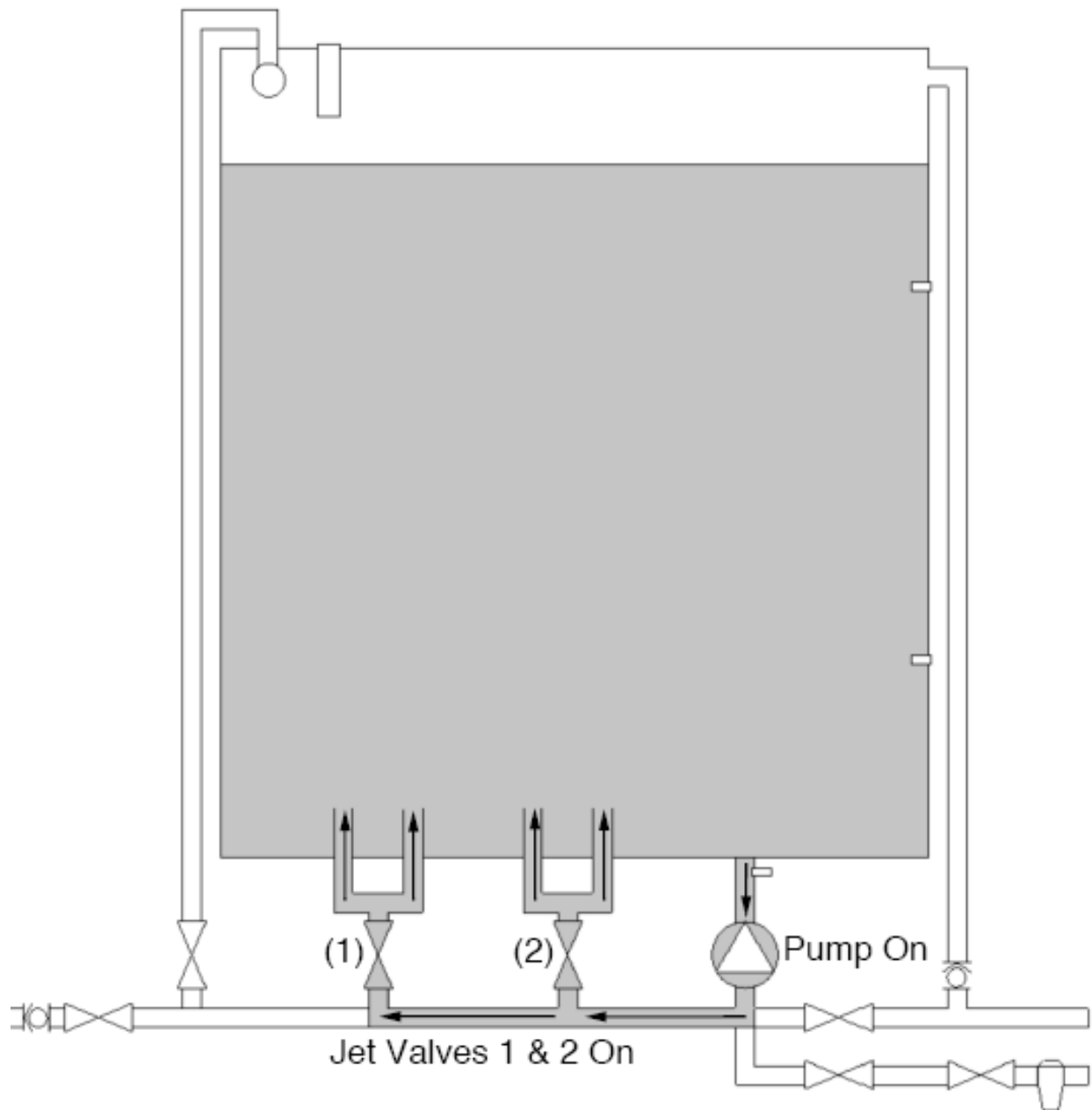

Jet Valves 1 and 2 open and the pump turns on. Mix mode is a timed 35 minute period.

DEAERATION MODE

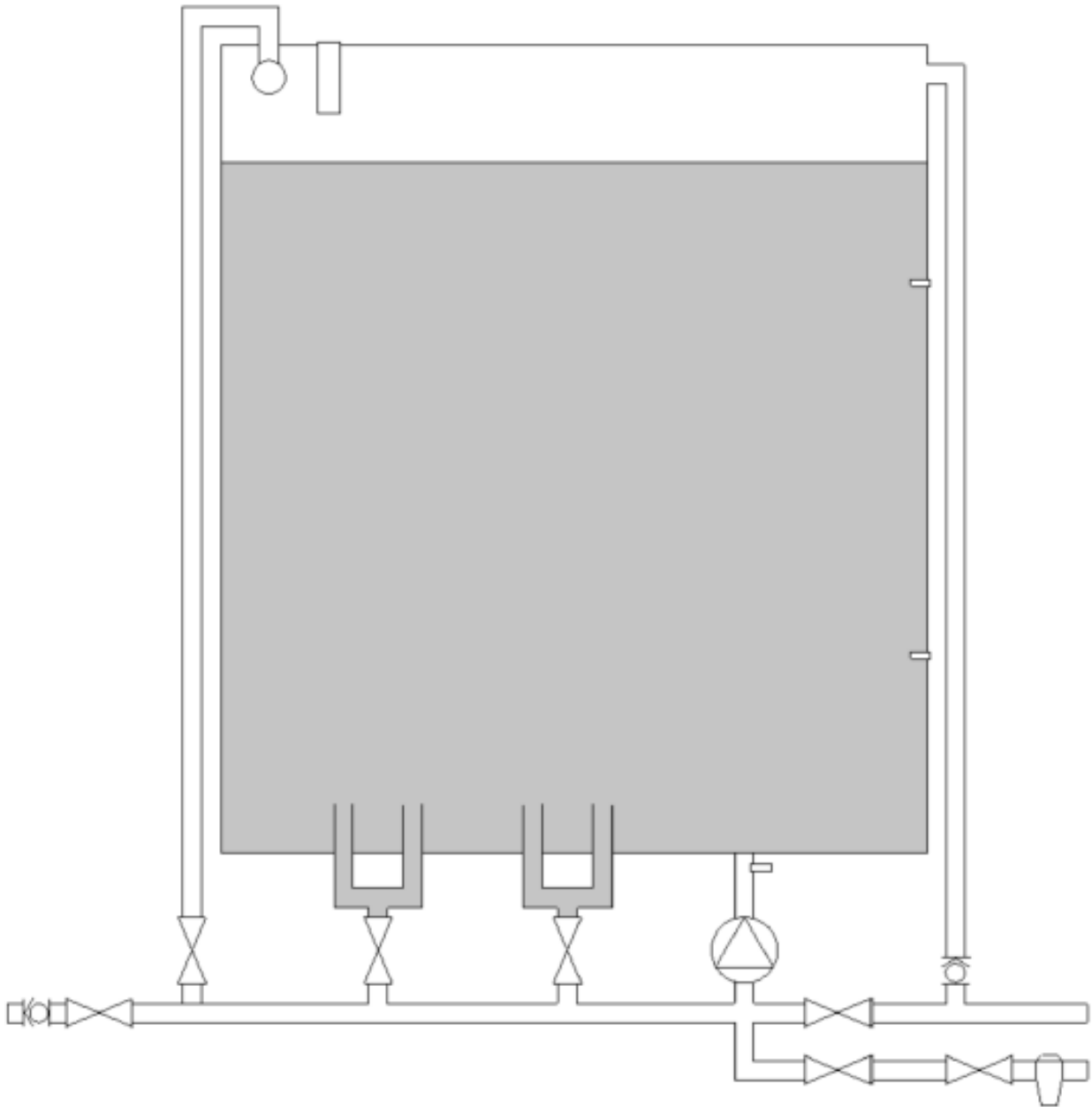

Deaeration LED is on. There is no hydraulic activity. This is a timed two minute period.

FINAL FILL MODE

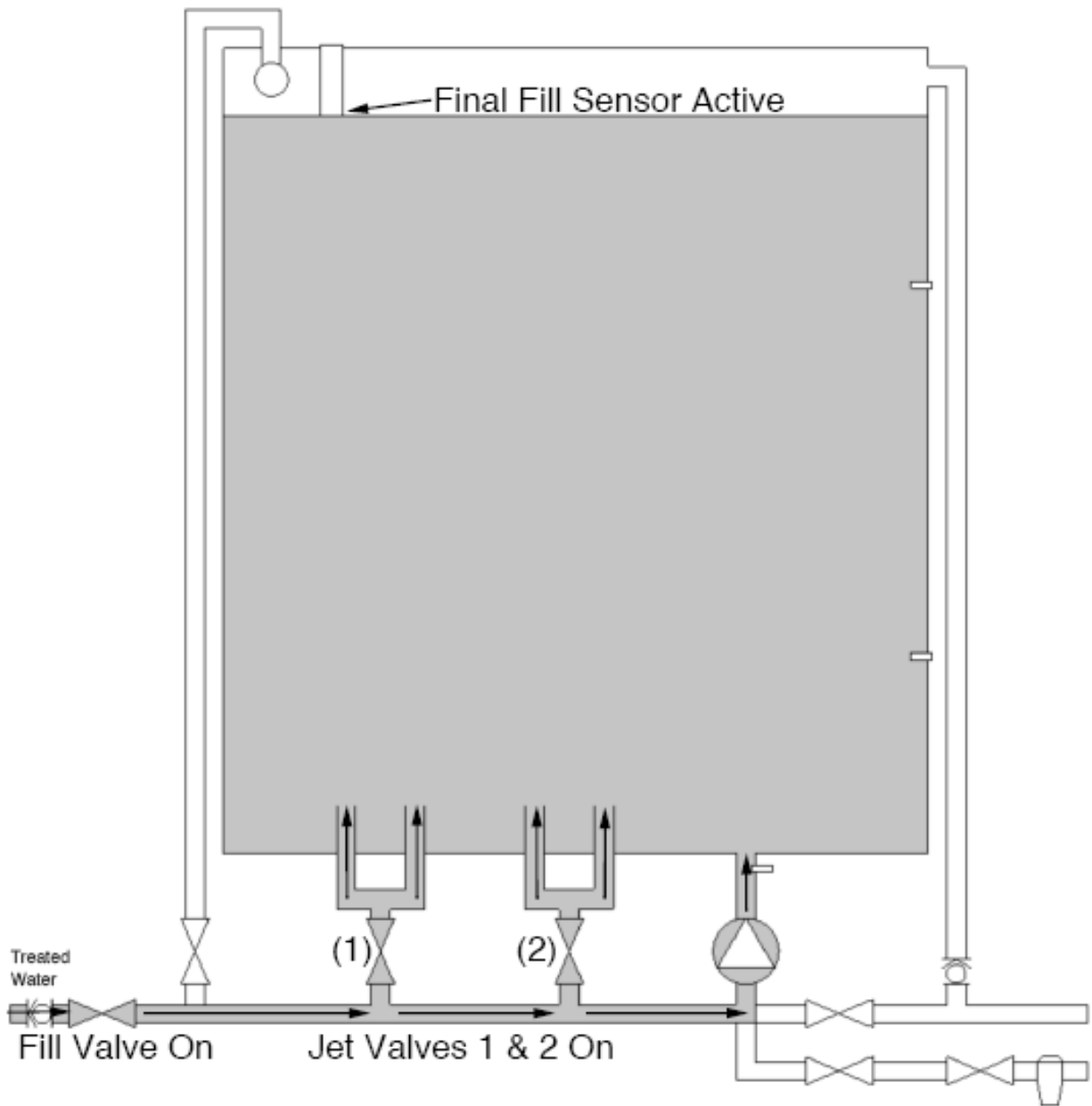

Fill Valve and Jet Valves 1 and 2 open. Treated water will flow through all four jets inside the tank, through the pump into the bottom of the tank, even though the pump is off.

HOMOGENIZE MODE

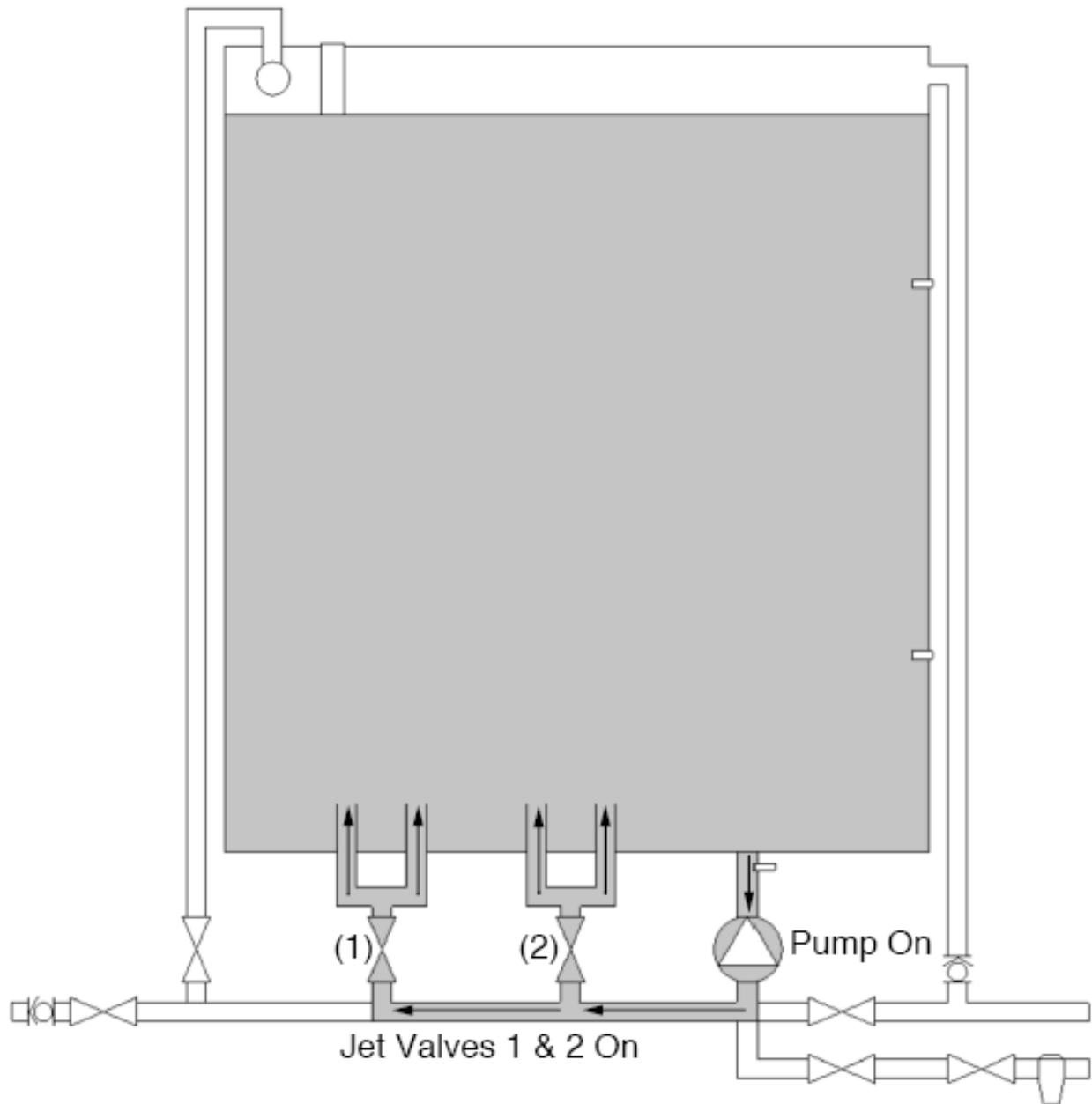

Jet Valves 1 and 2 open, and the pump turns on. This is a timed ten minute period.

TRANSFER MODE

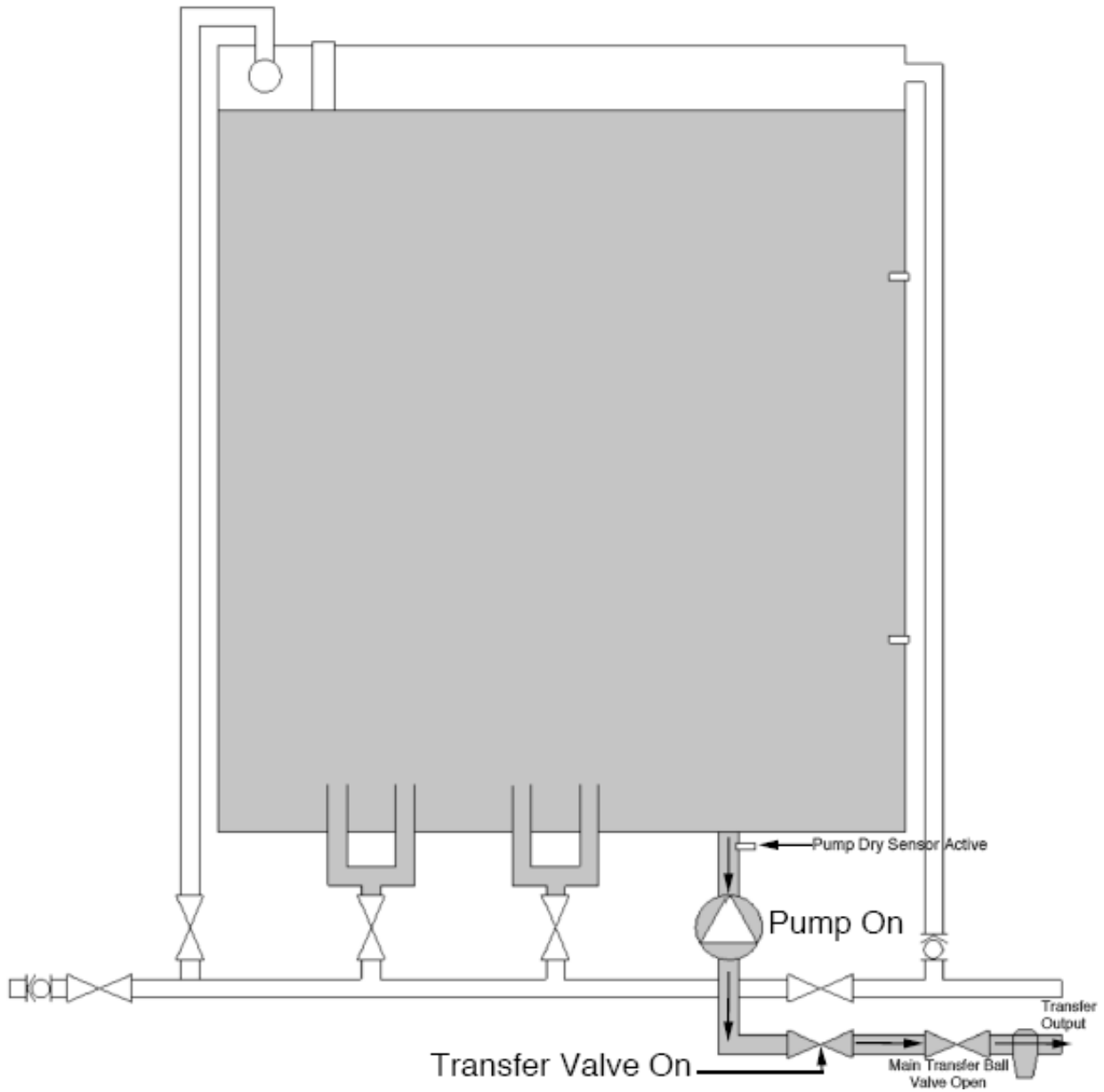

Transfer Valve opens and the pump turns on.

CYCLE COMPLETE MODE

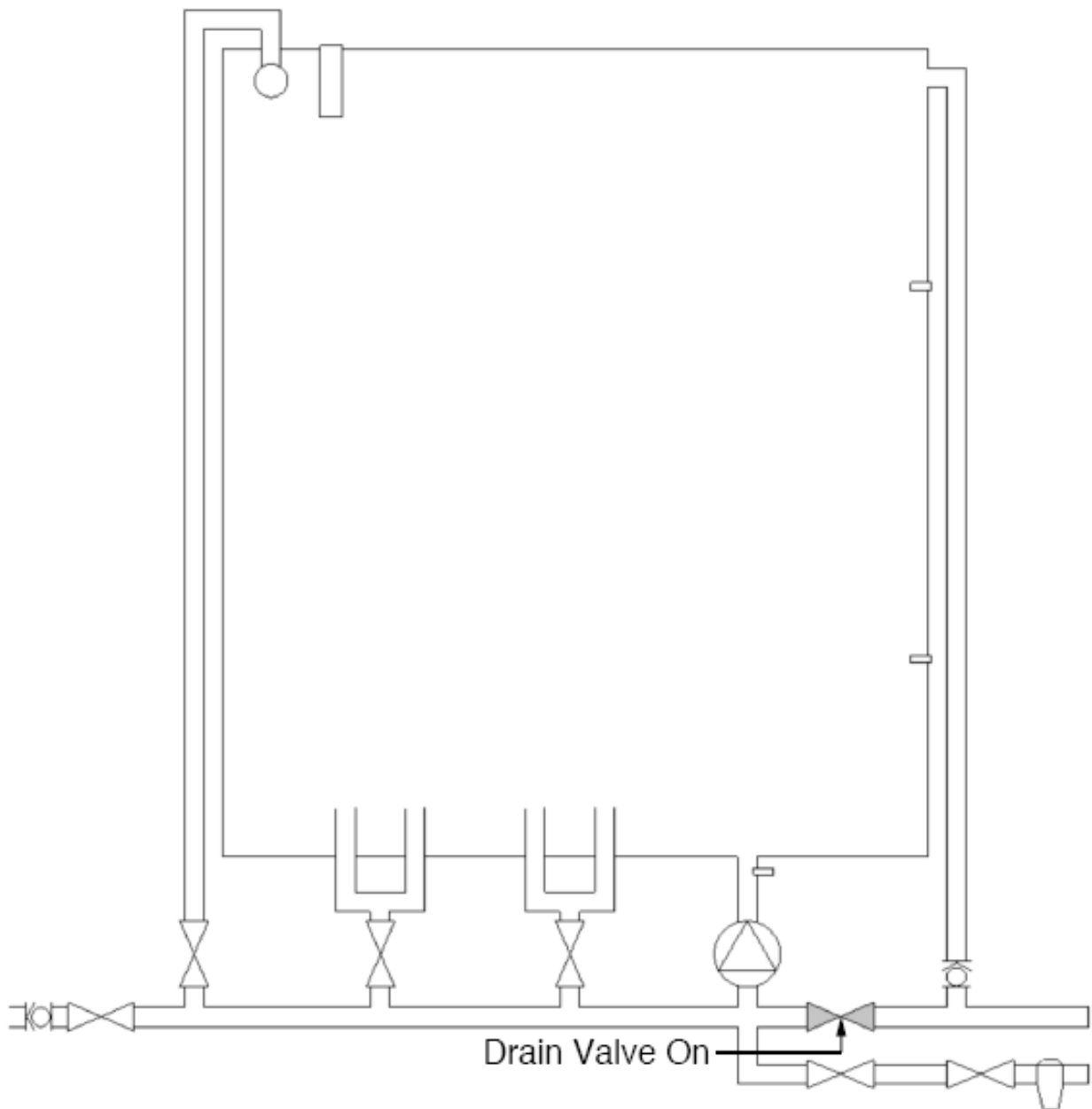

Cycle Complete – Drain Valve is open.

SECTION III - ELECTRONIC CIRCUIT DESCRIPTION

COMPONENT DESCRIPTION

1) Control Console



The Control Console is the blue shroud housing the electronics. This console has the user Control Panel on the outer top, a right side mounted Power Switch and the Control Board affixed on the inside. This blue shroud is attached to the main dissolution unit with 10 screws.

2) Power Switch



This is a 120 VAC, 10 amp Power Switch with a built-in 30 second circuit breaker. If the current reaches 10 amps for 30 seconds the switch will open the circuit. The higher the current, the faster the switch will open the circuit. This switch has a factory mounted plastic cover and is located on the right side of the Control Console.

3) Control Board

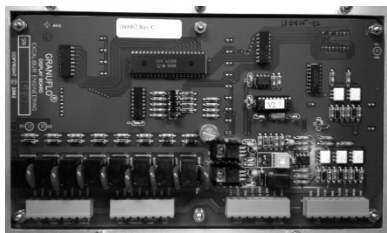

The Control Board is mounted inside the blue Control Console; it contains the necessary circuitry and software to enable mixer functions. All wiring connections for various components are connected to the bottom of the Control Board. The mixer software is a replaceable IC (EEPROM) that is located on the Control Board.

4) Control Panel

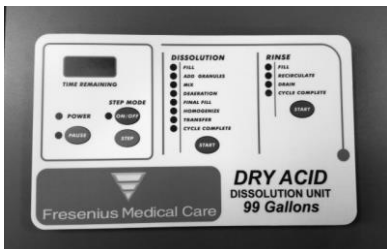

The Control Panel is the control interface for the user. The user can initiate, pause and step through Dissolution and Rinse cycles. The time remaining for any timed mode can be seen on a digital display and the current state of the mixer can be determined by LED indicators located on the panel.

10) Power Board

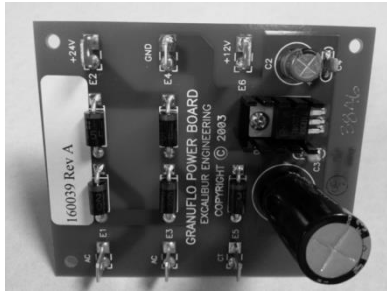

The Power Board is included in the Lower Power Supply. This board has a 12 VDC output at connector E6 which feeds into the Control Board for power distribution to all mixer sensors. This board also has an unused 24 VDC output at connector E2.

SECTION IV - MAINTENANCE



WARNING! TO PREVENT ACCIDENTAL SHOCK HAZARD, THIS DEVICE MUST BE PLUGGED INTO A PROPERLY GROUNDED GFI PROTECTED THREE WIRE RECEPTACLE AC CIRCUIT. DO NOT EMPLOY EXTENSION CORDS OF ANY KIND. WHEN THE POWER CORD IS NOT LONG ENOUGH TO BE SERVICEABLE, A LICENSED ELECTRICIAN MUST INSTALL A NEW THREE WIRE GROUNDED RECEPTACLE IN ACCORDANCE WITH THE NATIONAL ELECTRICAL CODE. DO NOT USE A THREE TO TWO PRONG PLUG ADAPTER WITH THIS DEVICE.

The Dry Acid Dissolution Unit (DADU) has been designed for ease of use and trouble free operation. However, a minimal amount of preventive maintenance is required in order to maintain the DADU in good working condition and minimize the possibility of a system malfunction.

The recommended program for proper care of the DADU consists of five basic steps. They are: (4.1) Regular visual inspection, (4.2) Cleaning, (4.3) Bleach Disinfection, (4.4) Filter Maintenance and (4.5) Clean and inspect Spray Ball.

4.1 VISUAL INSPECTION

Visually inspect the Dry Acid Dissolution Unit (DADU) prior to mixing a batch. The operator should look for any defects which may inhibit the safe or proper operation of the DADU. Items such as damaged hydraulic hoses or fittings, damaged electrical cables or connections, loose, missing or damaged hardware or process contamination should be corrected prior to the use of the DADU.

Should the power cord or plug become cracked, frayed or otherwise damaged, it should be replaced immediately. Tag the DADU "OUT of SERVICE" until the repair is made. Always remove the power cord from the power source before attempting to service this device. Never unplug the DADU by pulling on the power cord.

4.2 CLEANING

Clean the exterior surface of the DADU thoroughly after each batch of concentrate is mixed. If necessary a mild detergent solution may be used to clean the exterior surface. Care should be taken not to contaminate the system interior. All spills should be wiped off immediately. Spillage at the Control Panel should be avoided in order to minimize the possibility of electrical malfunction.



CAUTION! DO NOT USE CHEMICAL CLEANING AGENTS THAT MAY DAMAGE THE MATERIAL USED IN THE DRY ACID DISSOLUTION UNIT. AGENTS WHICH CONTAIN *BENZENE, TOLUENE, XYLENE, ACETONE* OR ANY OTHER *AROMATIC OR KETONE SOLVENTS* MUST BE AVOIDED.

4.3 BLEACH DISINFECTION



WARNING! USE ONLY BLEACH (SODIUM HYPOCHLORITE 5% TO 10% WITHOUT ADDITIVES SUCH AS DETERGENTS OR FRAGRANCES) TO DISINFECT THE DRY ACID DISSOLUTION UNIT.



WARNING! ENSURE THE TRANSFER LINE IS NOT CONNECTED TO A CONCENTRATE STORAGE CONTAINER/TANK.

1. To start the disinfection process, power OFF the Dry Acid Dissolution Unit (DADU), remove the Filter Housing and discard the filter. Place the residual fluid from the Filter Housing in a Residual Solution Bucket (see Operator's Manual PN 460017 for proper disposal of Residual Solution Bucket). Reinstall Filter Housing, but do not insert a filter at this time. Connect the Transfer Nozzle to the end of the DADU's Transfer Hose and make sure the valve on the Transfer Nozzle is CLOSED. In addition, loosen the Small Access Port Lid, but leave it in place. Ensure you are wearing appropriate personal protective equipment.



NOTE: A RINSE CYCLE DOES TWO COMPLETE RINSES THAT RUN CONSECUTIVELY. THE 1ST RINSE CONSISTS OF FILL, RECIRCULATION, AND DRAIN. THE 2ND RINSE CONSISTS OF FILL, RECIRCULATION, DRAIN, AND CYCLE COMPLETE.

2. Turn the power ON and ensure that the water supply valve is OPEN then press the Rinse START button. The Fill LED will turn on indicating the RINSE Cycle has started and the DADU is in FILL Mode (Figure 1).

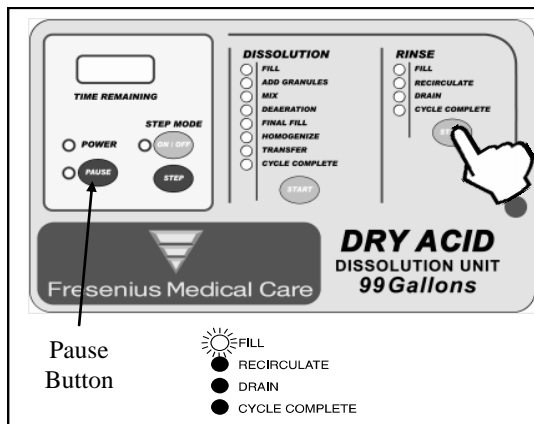

Figure 1

The Dry Acid Dissolution Unit will fill to the 25 GALLON LEVEL SENSOR.

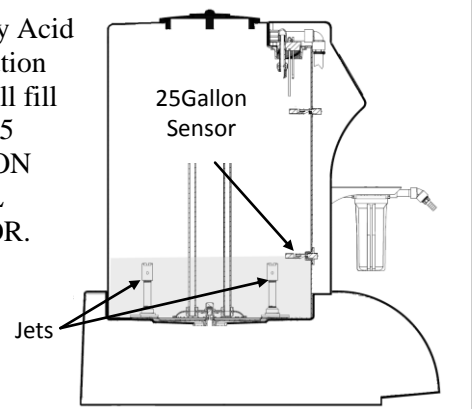

Figure 2

3. Once the 25 Gallon Sensor is reached (Figure 2), the Control Panel will advance to the first RECIRCULATE Mode. With your safety glasses on, lift the Small Access Port Lid and check for correct Spray Ball operation. See section 5.5 for the illustration of correct and incorrect Spray Ball operation.
4. During the second RINSE Cycle, when in RECIRCULATE Mode, press the PAUSE button (the PAUSE LED will turn on), then add 0.5 gallons (1.9 liters) of bleach to the rinse water in the Dissolution Tank. Once the bleach is added, press the RINSE START button (the PAUSE LED will turn off) and the RINSE Cycle will continue.
5. When the RINSE Cycle is complete, the CYCLE COMPLETE LED is on. Initiate and complete two RINSE Cycles consecutively by following the Operator's Manual P/N 460017.
 - While you are waiting for these two RINSE Cycles to complete, acquire and clean the hydrometer cylinder with purified water before using in the following step. The purified water source must meet ANSI/AAMI or ISO standards for dialysis currently ANSI/AAMI RD62, or ISO 13959.
6. When the two RINSE Cycles are complete, the RINSE Cycle, CYCLE COMPLETE LED is on. Use the appropriate chlorine test strips to check for the proper chlorine level at both Transfer Hose and Drain Hose.

7. To Check for residual bleach from the Transfer Hose:
 - Have chlorine test strip ready for use
 - Press DISSOLUTION Cycle START button.
 - When water has reached the 25 Gallon Sensor, press the STEP Mode ON/OFF button until the STEP Mode LED turns on.
 - Use the STEP button to step to TRANSFER Mode, the TRANSFER LED will be flashing.
 - Press the DISSOLUTION Cycle START button. The TRANSFER LED will be on (no longer flashing), the Transfer Valve will open and the Pump will turn on.
 - OPEN the Main Transfer Ball Valve on the DADU.
 - With the end of the Transfer Nozzle placed over a drain, slowly OPEN the valve on the Transfer Nozzle. Allow water to flow to the drain for 15 seconds.
 - Adjust the output of the Transfer Nozzle to a slow output flow.
 - Place chlorine test strip under the flow for 30 seconds or the time interval recommended by the manufacturer of the test strip being used.
 - CLOSE Transfer Nozzle Valve and press the PAUSE button (the PAUSE LED will turn on).
 - Ensure that you check the results of the test strip immediately. If the results are higher than 0.1 ppm (ANSI/AAMI RD61: 2006) go to step 9
 - Before proceeding to step 8, ensure the Drain Hose is secure to prevent the hose from flailing around during the DRAIN Mode.
8. To check for residual bleach from the Drain Hose:
 - Have chlorine test strip and hydrometer cylinder ready for use
 - Using STEP button, step to the DRAIN Mode.
 - Press the RINSE Cycle START button.
 - PAUSE LED will turn off, the Drain Valve will open and the Pump will turn on. Allow water to drain for 15 seconds.
 - Press PAUSE button, then quickly collect sample into the hydrometer cylinder.
 - Once you have collected a sample, pour the sample slowly over the chlorine test strip for 30 seconds.
 - Ensure that you check the results of the test strip immediately. If the results are higher than 0.1 ppm (ANSI/AAMI RD61: 2006) go to step 9, otherwise go to step 10.
9. If residual bleach levels are higher than *ANSI/AAMI* Standard limit of 0.1 ppm (RD61: 2006), at either the Transfer or Drain Hose initiate another complete RINSE Cycle. After the RINSE Cycle is complete, start from section 5.3, step #5, to check for residual bleach. Continue the RINSE Cycle and test procedure until residual bleach levels are within *ANSI/AAMI* Standard limit of less than 0.1 ppm (RD61:2006) at the end of the Transfer and Drain Hose.
10. Once you have attained an acceptable residual bleach level, replace the drain hose, and press the RINSE Cycle START button. Press and hold the STEP Mode ON/OFF button until the STEP LED turns off. Allow the contents of the DADU to drain and wait for the Rinse Cycle to complete. The CYCLE COMPLETE LED will turn on.
11. Turn OFF the power to the DADU and CLOSE the Main Transfer Ball Valve near the Filter Housing. Then connect the Transfer Hose to the Transfer Hose Holder.
12. Remove Filter Housing and drain all residual water from the Housing. Install new filter and tighten Filter Housing into place. See Figure 3.

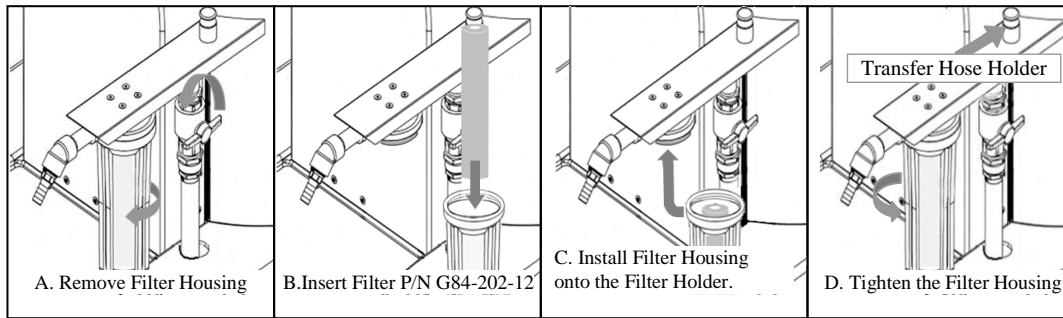

Figure 3

13. Immediately after a successful disinfection procedure, make a batch of Dry Acid Product. Leaving the DADU with only treated water or wetted with only treated water leaves the DADU susceptible to bacterial growth.



WARNING! DO NOT ALLOW THE UNIT TO REMAIN FULL OF TREATED WATER WITHOUT THE ADDITION OF FRESenius MEDICAL CARE DRY ACID PRODUCT. BACTERIAL GROWTH MAY OCCUR.

4.4 TRANSFER FILTER AND STANDPIPE ASSEMBLY FILTER MAINTENANCE

The 1 micron filter (P/N G84-202-12) should be changed under the following conditions:

1. After mixing 6 batches of Dry Acid concentrate.
2. When the Dry Acid Dissolution Unit (DADU) requires disinfection.

4.4.1. TRANSFER FILTER REMOVAL AND REPLACEMENT

Ensure the Dissolution Tank is empty and that power to the DADU is OFF and the Main Transfer Ball Valve is CLOSED. Follow figures A, B, C, and D for removal and replacement of the filter (Figure 4). If the residual fluid in the Filter Housing is concentrate, then place the solution in the Residual Solution Bucket (see Operator's Manual PN 460017 for proper disposal of Residual Solution Bucket).

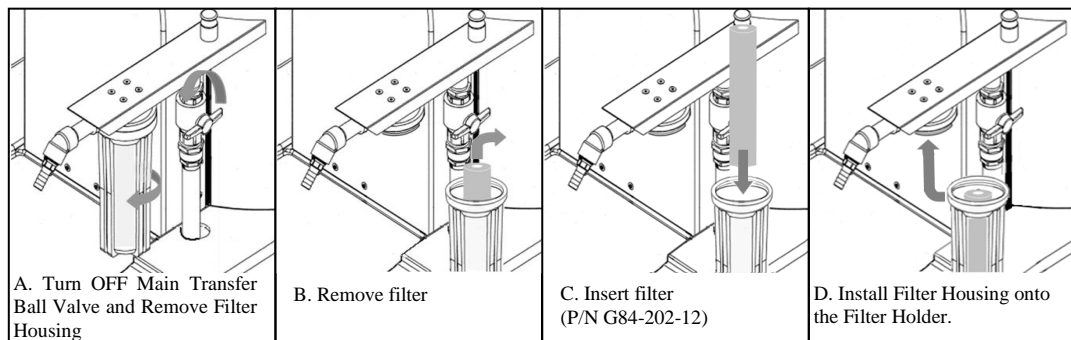

Figure 4



NOTE: THE FILTER USED MUST BE COMPATIBLE WITH FRESenius MEDICAL CARE DRY ACID PRODUCT AND RATED AT 1 MICRON. FRESenius MEDICAL CARE, PN G84-202-12, IS A POLYPROPYLENE FIBER WOUND ON A POLYPROPYLENE MESH CORE MEETS THESE REQUIREMENTS. CELLULOSE FILTERS ARE NOT COMPATIBLE WITH THE FRESenius MEDICAL CARE DRY ACID PRODUCT.



NOTE: IT IS RECOMMENDED TO REPLACE THE FILTER AFTER MIXING 6 BATCHES OR IF THE TANK REQUIRES DISINFECTION.

4.4.2. STANDPIPE ASSEMBLY FILTER REMOVAL

Using Base Filter Rod, P/N 260025 (Figure 5A), reach into the Dissolution Tank and connect the small end of the shaft into the Screw Nut of Standpipe Assembly (Figure 5B). Turn the Screw Nut counterclockwise until the Standpipe Assembly is no longer attached to the tank. Use the Base Filter Rod to help lift the Standpipe Assembly out of Dissolution Tank. Thoroughly clean off the top of the Pie Plate Filter holes by running purified water over the filter holes until all debris is removed. Once the Pie Plate Filter is clean reinstall the Standpipe Assembly Note: the Pie Plate Filter is part of Standpipe Assembly.

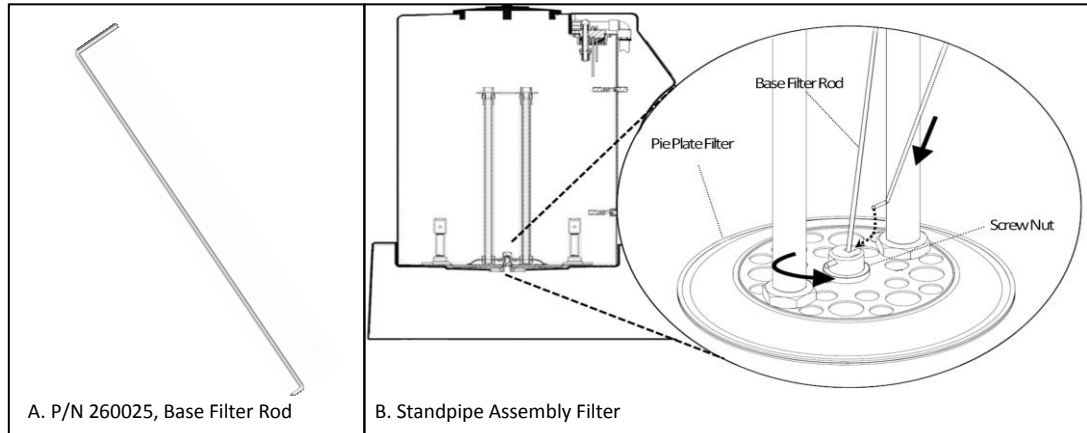
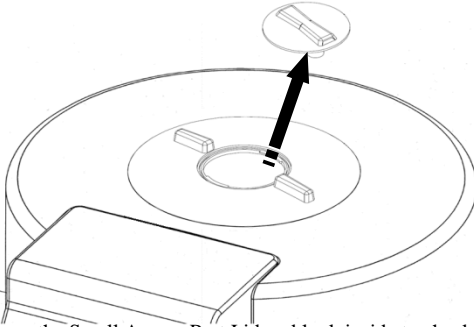
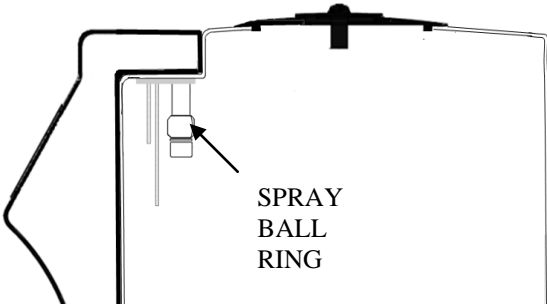
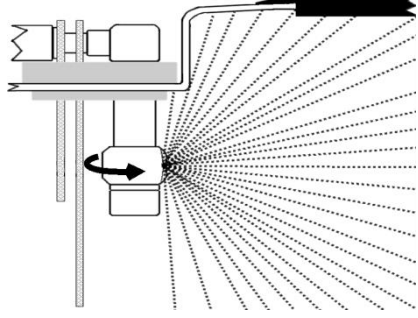
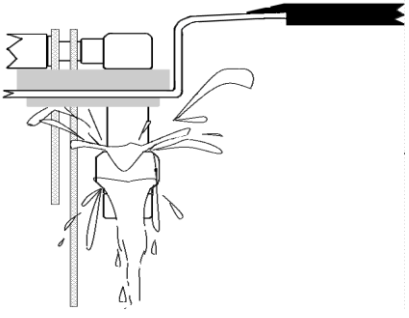
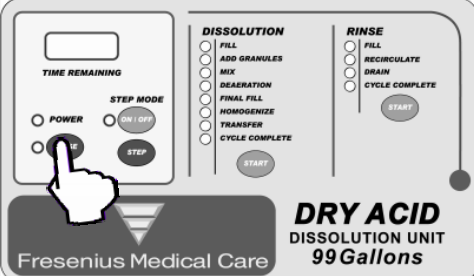
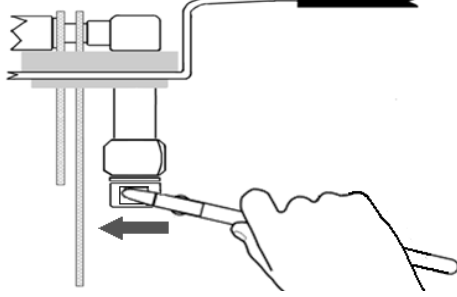
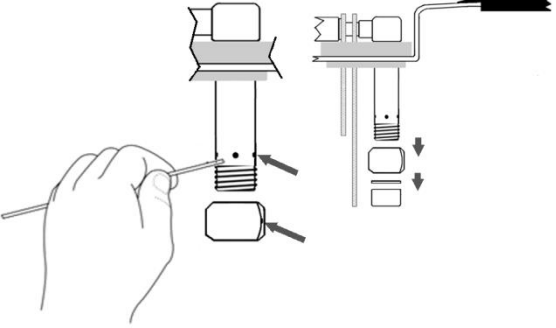
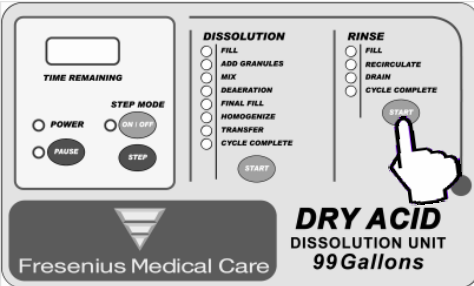

FIGURE 5

4.5 CLEAN AND INSPECT SPRAY BALL

 <p>A. Remove the Small Access Port Lid and look inside to check the Spray Ball Ring for proper rotation.</p>	 <p>B. Check the Spray Ball Ring for rotation.</p>
 <p>◆ If correct spray and rotation of the Spray Ball Ring is observed, then the inspection is complete.</p>	 <p>◆ If Spray Ball Ring is clogged the water flow looks like this, then proceed to C.</p>
 <p>C. If the Spray Ball is stationary, push the PAUSE button. RECIRCULATE LED will flash. Turn Main Power Switch OFF.</p>	 <p>D. Remove the nut below the Spray Ball to access the Sprayer.</p>
 <p>E. Clear the spray holes in both the Spray Ball Ring and Sprayer of debris and reassemble.</p>	 <p>F. Turn Main Power Switch ON. Press RINSE Cycle START button. PAUSE LED will turn off and RECIRCULATE LED will turn on. Check for proper Spray Ring rotation.</p>

ROUTINE MAINTENANCE SCHEDULE

PROCEDURE	PER BATCH	MONTHLY	AS NEEDED	REF. SECTION
RINSE CYCLE	X			Operators Manual part number 460017
VISUAL INSPECTION	X			4.1
CLEANING	X			4.2
BLEACH DISINFECT			X	4.3
TRANSFER FILTER			X*	4.4
STANDPIPE ASSEMBLY FILTER			X	4.4.2
SPRAY BALL INSPECTION			X	4.5
CORROSION		X**		N/A

* It is recommended to change the filter after mixing 6 batches or when the DADU requires disinfection. If the Dissolution Tank becomes contaminated, it will need to be disinfected before a new filter is installed.

** It is recommended that the Final Fill Sensor, connectors at every valve, and the unit's Dissolution Tank be checked for corrosion and salt deposits. Any excessively corroded part should be cleaned or replaced as needed

SECTION V - TROUBLESHOOTING

	Page
PUMP NOT RUNNING	V-2
FILL PROBLEMS	V-3
DRAIN PROBLEMS	V-7
TRANSFER PROBLEMS	V-8
POWER PROBLEMS	V-9



NOTE: THE DBJ CONNECTORS MENTIONED IN THIS TROUBLESHOOTING GUIDE ARE THE FOUR CONNECTORS ON THE BOTTOM OF THE CONTROL BOARD WHERE ALL WIRES ATTACH. THEY COUNT UP FROM LEFT TO RIGHT DBJ2, DBJ3, DBJ4 AND DBJ5. WHERE DBJ2 IS THE FAR LEFT CONNECTOR. SEE FIGURE 1 BELOW



NOTE: ALL PIN OUTS ON THE DBJ CONNECTORS OF THE CONTROL BOARD ARE COUNTED FROM RIGHT TO LEFT. PIN 1 IS THE PIN ON FAR RIGHT OF EACH CONNECTOR AND PIN 8 IS THE PIN ON THE FAR LEFT OF EACH CONNECTOR. SEE FIGURE 1 BELOW

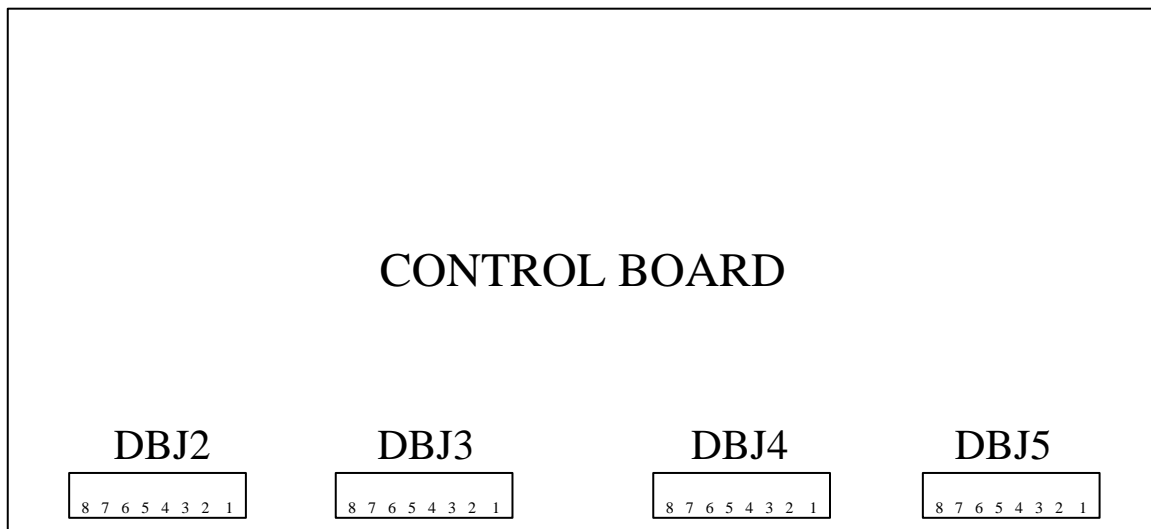

Figure 1.

PUMP NOT RUNNING



NOTE: THE DBJ CONNECTORS MENTIONED IN THIS TROUBLESHOOTING GUIDE ARE THE FOUR CONNECTORS ON THE BOTTOM OF THE CONTROL BOARD WHERE ALL WIRES ATTACH. THEY COUNT UP FROM LEFT TO RIGHT DBJ2, DBJ3, DBJ4 AND DBJ5. WHERE DBJ2 IS THE FAR LEFT CONNECTOR. SEE FIGURE 1.



NOTE: ALL PIN OUTS ON THE DBJ CONNECTORS OF THE CONTROL BOARD ARE COUNTED FROM RIGHT TO LEFT. PIN 1 IS THE PIN ON FAR RIGHT OF EACH CONNECTOR AND PIN 8 IS THE PIN ON THE FAR LEFT OF EACH CONNECTOR. SEE FIGURE 1

- 1.0 Verify that there is water in the Dissolution Tank. The machine should be in the Recirculate Mode (LED on – not flashing) of the Rinse Cycle.
 - 1.1 Locate connector DBJ3, measure the voltage between pins 1 and 2 (two gray wires). Is there 24 VDC?
 - Yes – Go to step 1.2
 - No - Go to step 1.3
 - 1.2 Turn OFF the machine and unplug the wires going to pins 2 and 4 of the Pump Relay (pins 4 and 8 on alternate relay PN 361017-09). These are the blue and brown wires going to the Pump. Turn the machine ON, in Recirculate Mode (LED on – not flashing) of Rinse Cycle, measure the voltage between the pins on the pump relay where the wires were plugged in. Is there 120 VAC?
 - Yes – Change the Pump
 - No – Change the Pump Relay
 - 1.3 While still in Recirculate Mode (LED on – not flashing) in the Rinse Cycle, locate connector DBJ4, measure between pins 6 and 8 (black and yellow wires). Is there 24 VDC?
 - Yes – Change the Control Board and software
 - No – Go to Power Problems troubleshooting step 5.12

FILL PROBLEMS



NOTE: THE DBJ CONNECTORS MENTIONED IN THIS TROUBLESHOOTING GUIDE ARE THE FOUR CONNECTORS ON THE BOTTOM OF THE CONTROL BOARD WHERE ALL WIRES ATTACH. THEY COUNT UP FROM LEFT TO RIGHT DBJ2, DBJ3, DBJ4 AND DBJ5. WHERE DBJ2 IS THE FAR LEFT CONNECTOR. SEE FIGURE 1.



NOTE: ALL PIN OUTS ON THE DBJ CONNECTORS OF THE CONTROL BOARD ARE COUNTED FROM RIGHT TO LEFT. PIN 1 IS THE PIN ON FAR RIGHT OF EACH CONNECTOR AND PIN 8 IS THE PIN ON THE FAR LEFT OF EACH CONNECTOR. SEE FIGURE 1.

- 2.0 Does the Dissolution Tank not fill or overflow?
- Does not fill – Go to step 2.1
 - Overfills – Go to step 2.13
- 2.1 Does the Dissolution Tank fill in the Rinse Cycle?
- Yes – Go to step 2.2
 - No – Go to step 2.7
- 2.2 After the pre-rinse (fill to 25 Gallon Sensor, 2 minute recirculation and drain) does the machine (a) stay in Fill Mode or (b) advance to Add Granules Mode with the Dissolution Tank still empty?
- (a) Stays in Fill Mode – Change the Control Board and software
 - (b) Advances to Add Granules Mode – Go to step 2.3
- 2.3 How many float switches are in the Dissolution Tank?
- One float switch – Go to step 2.4
 - Two float switches – Go to step 2.5
- 2.4 With the Dissolution Tank empty and the power OFF, locate the DBJ4 connector, disconnect the white wire from pin 3 and the black wire from pin 5. Measure the resistance between these two wires. Is it an electrical Open (OL on most meters)
- Yes – Change the Control Board and software
 - No – Do the Mid-Level Sensor Upgrade PN 160104
- 2.5 With the Dissolution Tank empty and the power OFF, unplug the Mid-Level Sensor from the wiring harness and measure the resistance between the two pins on the Mid-Level Sensor. Is it an electrical Open (OL on most meters)?
- Yes – Plug the Mid-Level Sensor back in and go to step 2.6
 - No – Change the Mid-Level Sensor

- 2.6 With the Dissolution Tank empty and the power OFF, locate connector DBJ4, disconnect the red/orange wires from pins 3 and 5. Measure the resistance between these two wires. Is it an electrical Open (OL on most meters)?
- Yes – Change the Control Board and software
 - No – Change the Mid-Level Sensor wiring harness
- 2.7 Does the LED on the Control Panel (a) stay in Fill Mode or (b) advance to Recirculate Mode?
- (a) Stays in Fill Mode – Go to step 2.8
 - (b) Advances to Recirculate Mode– Go to step 2.11
- 2.8 While still in Fill Mode (LED on – not flashing) in the Rinse Cycle, locate connector DBJ2, measure between pins 7 and 8 (two brown wires). Is there 24 VDC?
- Yes – Go to step 2.9
 - No – Go to step 2.10
- 2.9 Turn power OFF. Unplug the Fill Valve from the wiring harness. Restart Fill Mode (LED on – not flashing) in the Rinse Cycle. Measure the voltage between the two wires of the wiring harness. Is there 24 VDC?
- Yes – Verify that the incoming water is turned on then change the Fill Valve or the incoming water check valve
 - No – Change the machine wiring harness
- 2.10 While still in Fill Mode (LED on – not flashing) in the Rinse Cycle, locate connector DBJ4, measure the voltage between pins 6 and 8 (black and yellow wires). Is there 24 VDC?
- Yes – Change the Control Board and software
 - No – Go to Power Problems troubleshooting step 5.12
- 2.11 With the Dissolution Tank empty and the power OFF, unplug the 25 Gallon Sensor from the wiring harness and measure the resistance between the two pins on the 25 Gallon Sensor. Is it an electrical Open (OL on most meters)?
- Yes – Plug the 25 Gallon Sensor back in and go to step 2.12
 - No – Change the 25 Gallon Sensor
- 2.12 With the Dissolution Tank empty and the power OFF, locate connector DBJ4, disconnect the white/brown wires from pins 1 and 2. Measure the resistance between these two wires. Is it an electrical Open (OL on most meters)?
- Yes – Change the Control Board and software
 - No – Change the machine wiring harness

- 2.13 When does the Dissolution Tank overflow?
- (a) Power OFF – Go to step 2.17
 - (b) Fill Mode – Rinse Cycle or during pre-rinse - Dissolution Cycle - Go to step 2.14
 - (c) Fill Mode – Dissolution Cycle to the Mid-Level Sensor (after pre-rinse) - Go to step 2.20
 - (d) Final Fill Mode – Dissolution Cycle - Go to step 2.25
- 2.14 When in Fill Mode (LED on) in the Rinse Cycle (not the Dissolution Cycle) does it: (a) fill past the 25 Gallon Sensor, or (b) advance to Recirculate Mode (LED on) when the water reaches the 25 Gallon Sensor, but continues filling during Recirculate Mode?
- (a) Fill Mode (LED on) and continues filling – Go to step 2.15
 - (b) Recirculate Mode (LED on) and continues filling – Go to step 2.17
- 2.15 With the water up to or past the 25 Gallon Sensor and the power turned OFF unplug the 25 Gallon Sensor from the wiring harness and measure the resistance between the two pins on the 25 Gallon Sensor. Is it electrically closed (< 0.5 ohms)?
- Yes – Plug the 25 Gallon Sensor back into the wiring harness and go to step 2.16
 - No – Change the 25 Gallon Sensor
- 2.16 With the water still up to or past the 25 Gallon Sensor and the power turned OFF, locate connector DBJ4, disconnect the white and brown wires from pins 1 and 2. Measure the resistance between these two wires. Is it electrically closed (<0.5 ohms)?
- Yes – Change the Control Board and software
 - No – Change the machine wiring harness
- 2.17 Is the incoming water pressure to the machine less than 60 psi?
- Yes – Go to step 2.18
 - No – Regulate water pressure to the mixer to less than 60 psi.
Note: partially closing water supply valve on the wall does not regulate pressure.
- 2.18 Is the software version 2.7 or higher (shows on Control Panel during power up)?
- Yes – Go to step 2.19
 - No – Upgrade software to version 2.7 or higher
- 2.19 Does the machine have the type 2 Fill Valve i.e. does the Fill Valve look different from the other four solenoid valves?
- Yes – Change the Fill Valve
 - No – Do the Fill Valve Conversion P/N 160125
- 2.20 While in Fill Mode (LED on) in the Dissolution Cycle (after the pre rinse), when the water reaches the Mid-Level Sensor, (a) does it stay in Fill Mode (LED on) while the Dissolution Tank continues to fill or (b) does it advance Add Granules Mode while the Dissolution Tank continues to fill?
- (a) Stays in Fill Mode (LED on) – Go to step 2.21
 - (b) Advances to Add Granules Mode (LED on) – Go to step 2.17

2.21 How many float switches are in the Dissolution Tank?

One float switch – Go to step 2.22

Two float switches – Go to step 2.23

2.22 With the water past the Mid-Level Sensor (two long metal rods hanging down from the top of the tank) and the power OFF, locate connector DBJ4, disconnect the white wire from pin 3 and the black wire from pin 5. Measure the resistance between these two wires. Is it electrically closed (< 0.5 ohms)?

Yes – Change the Control Board and software

No – Do the Mid-Level Sensor upgrade PN 160104

2.23 With the water past the Mid-Level Sensor and the power OFF, unplug the Mid-Level Sensor from the wiring harness. Measure the resistance between these two pins on the Mid-Level Sensor. Is it electrically closed (< 0.5 ohms)?

Yes – Plug the Mid-Level Sensor back in and go to step 2.24

No – Change the Mid-Level Sensor

2.24 With the water still past the Mid-Level Sensor and the power OFF, locate connector DBJ4, disconnect the red/orange wires from pins 3 and 5. Measure the resistance between these two wires. Is it electrically closed (< 0.5 ohms)?

Yes – Change the Control Board and software

No – Change the Mid-Level Sensor wiring harness

2.25 While in Final Fill Mode (LED on), when the acid concentrate reaches the Final Fill Sensor does: (a) the Dissolution Tank continues to fill or (b) does the cycle advance to Homogenize Mode while the Dissolution Tank continues to fill?



NOTE: ACID CONCENTRATE (OR A JUMPER WIRE ACROSS THE PROBES OF THE FINAL FILL SENSOR) MUST BE USED IN THIS STEP. WITH RO WATER ONLY IT IS NORMAL FOR THE TANK TO OVERFILL IN FINAL FILL.

(a) Stays in Final Fill Mode – Go to step 2.26

(b) Advances to Homogenize Mode – Go to step 2.17

2.26 Drain the Dissolution Tank. Turn the power OFF, and wipe off the Final Fill Sensor. Using a jumper wire, directly connect (jumper) the straight and U shaped probes of the Final Fill Sensor. Disconnect the red and white wires from the Final Fill Sensor. Measure the resistance between the prongs on the Final Fill Sensor. Is it electrically closed (< 0.5 ohms)?

Yes – Go to step 2.27

No – Contact Technical Support at (800)227-2572 option 4

2.27 With the power OFF and the Final Fill Sensor still jumped with a jumper wire, reconnect the red and white wires to the Final Fill Sensor. Locate connector DBJ4, disconnect the red wire from pin 4 and the white wire from pin 3. Measure the resistance between these two wires. Is it electrically closed (< 0.5 ohms)?

Yes – Change the Control Board and software

No – Change the machine wiring harness

DRAIN PROBLEMS



NOTE: THE DBJ CONNECTORS MENTIONED IN THIS TROUBLESHOOTING GUIDE ARE THE FOUR CONNECTORS ON THE BOTTOM OF THE CONTROL BOARD WHERE ALL WIRES ATTACH. THEY COUNT UP FROM LEFT TO RIGHT DBJ2, DBJ3, DBJ4 AND DBJ5. WHERE DBJ2 IS THE FAR LEFT CONNECTOR. SEE FIGURE 1.



NOTE: ALL PIN OUTS ON THE DBJ CONNECTORS OF THE CONTROL BOARD ARE COUNTED FROM RIGHT TO LEFT. PIN 1 IS THE PIN ON FAR RIGHT OF EACH CONNECTOR AND PIN 8 IS THE PIN ON THE FAR LEFT OF EACH CONNECTOR. SEE FIGURE 1.

- 3.0 Does the Drain Valve leak or not open?
- Leaks – Go to step 3.1
 - Does not open – Go to step 3.4
- 3.1 Advance to Cycle Complete Mode (LED on) of either cycle, wait 10 seconds for the Drain Valve to fully open and reset itself. Start Fill Mode (LED on) in the Rinse Cycle. Does the Drain Valve continue to leak?
- Yes – Go to step 3.2
 - No – Drain Valve was misaligned. To prevent future occurrences, always wait 10 seconds when switching or stepping between Cycles or Modes.
- 3.2 While still in Fill Mode (LED on) of the Rinse Cycle, turn OFF the incoming water, locate connector DBJ2, measure the voltage between pins 5 and 6 (violet and green wires). Is there 24 VDC?
- Yes – Change the Control Board and software
 - No – Go to step 3.3
- 3.3 Turn the power OFF and unplug the black wire marked “Relay NC” from the Drain Valve Relay. Turn the power back ON. With the incoming water still off, start the Fill Mode (LED on – not flashing) of the Rinse Cycle. Check for 24 VDC between the “Relay NC” connector of the Drain Valve Relay (where the black wire was plugged in) and pin 8 (yellow wire) of the DBJ4 connector of the Control Board. Is there 24 VDC?
- Yes – Change the Drain Valve or the Drain Check Valve
 - No – Change the Drain Valve Relay
- 3.4 While in Cycle Complete Mode (LED on – not flashing) of the Rinse Cycle, locate connector DBJ2, measure the voltage between pins 5 and 6 (violet and green wires). Is there 24 VDC?
- Yes – Go to step 3.5
 - No – Change the Control Board and software
- 3.5 Turn the power OFF and unplug the red wire marked “Relay NO” from the Drain Valve Relay. Turn the power back ON. While in Cycle Complete Mode (LED on) of the Rinse Cycle measure between the “Relay NO” connector of the Drain Valve Relay (where the red wire was plugged in) and pin 8 (yellow wire) of the DBJ4 connector of the Control Board. Is there 24 VDC?
- Yes – Change the Drain Valve or the Drain Check Valve
 - No – Change the Drain Valve Relay

TRANSFER PROBLEMS



NOTE: THE DBJ CONNECTORS MENTIONED IN THIS TROUBLESHOOTING GUIDE ARE THE FOUR CONNECTORS ON THE BOTTOM OF THE CONTROL BOARD WHERE ALL WIRES ATTACH. THEY COUNT UP FROM LEFT TO RIGHT DBJ2, DBJ3, DBJ4 AND DBJ5. WHERE DBJ2 IS THE FAR LEFT CONNECTOR. SEE FIGURE 1.



NOTE: ALL PIN OUTS ON THE DBJ CONNECTORS OF THE CONTROL BOARD ARE COUNTED FROM RIGHT TO LEFT. PIN 1 IS THE PIN ON FAR RIGHT OF EACH CONNECTOR AND PIN 8 IS THE PIN ON THE FAR LEFT OF EACH CONNECTOR. SEE FIGURE 1.

- 4.0 Does the Dissolution Tank (a) stay in Transfer Mode with no fluid moving or (b) advance to Cycle Complete Mode with fluid still in the Dissolution Tank?
- (a) Stays in Transfer Mode– Go to step 4.1
 - (b) Advances to Cycle Complete Mode – Go to step 4.5
- 4.1 Do you hear the Pump running?
- Yes – Go to step 4.2
 - No – Go to step 1.0 (Pump Not Running problems)
- 4.2 While in Mix Mode (LED on – not flashing) of the Dissolution Cycle, is there fluid moving in the Dissolution Tank?
- Yes – Go to step 4.3
 - No – Change the Pump and go to step 4.6 to check the function of the Pump Dry Sensor.
- 4.3 While in Transfer Mode (LED on – not flashing), locate connector DBJ3, measure the voltage between pins 5 and 6 (two blue wires). Is there 24 VDC?
- Yes – Change the Transfer Valve.
 - No – Go to step 4.4
- 4.4 While in Transfer Mode (LED on – not flashing), locate connector DBJ4, measure the voltage between pins 6 and 8 (black and yellow wires). Is there 24 VDC?
- Yes – Change the Control Board and software.
 - No – Go to Power Problems troubleshooting step 5.12
- 4.5 With the power ON and some liquid in the Dissolution Tank (any amount is OK as long as it is visible), locate connector DBJ5, measure the voltage between pins 7 and 8 (blue and black wires). Is there 12 VDC? Note: The machine does not need to be in any specific mode.
- Yes – Change the Control Board and software
 - No – Change the Pump Dry Sensor assembly
- 4.6 While in Drain Mode of the Rinse Cycle and water in the Dissolution Tank. Does the Pump shut off within 30 seconds after the Dissolution Tank is empty?
- Yes – Pump Dry Sensor is working fine.
 - No – Change the Pump Dry Sensor assembly.

POWER PROBLEMS



NOTE: THE DBJ CONNECTORS MENTIONED IN THIS TROUBLESHOOTING GUIDE ARE THE FOUR CONNECTORS ON THE BOTTOM OF THE CONTROL BOARD WHERE ALL WIRES ATTACH. THEY COUNT UP FROM LEFT TO RIGHT DBJ2, DBJ3, DBJ4 AND DBJ5. WHERE DBJ2 IS THE FAR LEFT CONNECTOR. SEE FIGURE 1.



NOTE: ALL PIN OUTS ON THE DBJ CONNECTORS OF THE CONTROL BOARD ARE COUNTED FROM RIGHT TO LEFT. PIN 1 IS THE PIN ON FAR RIGHT OF EACH CONNECTOR AND PIN 8 IS THE PIN ON THE FAR LEFT OF EACH CONNECTOR. SEE FIGURE 1.

- 5.0 Does the machine have (a) no power, (b) trips the circuit breaker or (c) have a 24 VDC problem?
- (a) No power – Go to step 5.1
 - (b) Trips the circuit breaker – Go to step 5.8
 - (c) 24 VDC problem – Go to step 5.12
- 5.1 With the power ON, locate connector DBJ4, measure the voltage between pins 6 and 7 (orange and black wires). Is there 12 VDC?
- Yes – Change the Control Board and software
 - No – Go to step 5.2
- 5.2 Unplug the machine from the wall outlet and remove fuse 1 (fuse on the left) from the Lower Power Supply. Measure the resistance of the fuse. Is it an electrical open (OL on most meters) or closed (less than 0.5 ohms)?
- Open – Change the fuse
 - Closed – Reinstall the fuse, plug the machine into the wall outlet and go to step 5.3
- 5.3 With power ON, measure between pins P4 (blue wire on right) and P6 (brown wire on bottom right) of the Barrier Strip in the Lower Power Supply. Is there 120 VAC?
- Yes – Go to step 5.4
 - No – Change the Power Cord
- 5.4 With power ON, measure between pins P4 (blue wire on right) and P2 (brown wire on top right) of the Barrier Strip in the Lower Power Supply. Is there 120 VAC?
- Yes – Go to step 5.5
 - No – Change the Power Switch
- 5.5 With power OFF, unplug the machine from the wall outlet. Unplug the brown, blue and black wires from pins E1, E3 and E5 of the Power Board. Plug the machine in to wall outlet, turn power ON. Measure the AC voltage between brown and blue wires. Is there 24 VAC?
- Yes – Go to set 5.6
 - No – Change the Transformer

- 5.6 Measure the AC voltage between black and blue wires from the Transformer. Is there 12 VAC?
- Yes – With the machine unplugged from wall outlet, plug the brown (E1), blue (E3) and black (E5) wires into the Power Board and go to step 5.7
No – Change the Transformer
- 5.7 With the machine unplugged from the wall outlet, unplug the black and orange wires from pins E4 and E6 of the Power Board. With the machine plugged in and ON measure the DC voltage between pins E4 and E6 of Power Board. Is there 12 VDC?
- Yes – Change the machine wiring harness
No – Change the Power Board
- 5.8 With the machine unplugged from the wall outlet, remove fuse 1 (fuse on left) from the Lower Power Supply. Locate the Barrier Strip, disconnect the blue wire from the primary of the Transformer from pin 3 (blue wire on left). Leave the second blue wire going to the Pump Relay connected to pin 3 of the Barrier Strip. Plug the machine in to the wall outlet and turn the power ON. Does it still trip the circuit breaker?
- Yes – Go to step 5.9
No – Change the Transformer
- 5.9 With the machine unplugged from the wall outlet, replace fuse 1 and the blue wire to pin 3 of the Barrier Strip. Remove the fuse 2 (fuse on right) from the Lower Power Supply. Locate the Barrier Strip disconnect the blue wire from pin 4 (blue wire on right), this comes from the Upper Power Supply. The second blue wire (going to Power Plug) remains connected to pin 4 of the Barrier Strip. Plug the machine into the wall outlet and turn the power ON. Does it trip the circuit breaker?
- Yes – Go to step 5.10
No – Change the Upper Power Supply
- 5.10 With the machine unplugged from the wall outlet, replace fuse 2 and the blue wire (from Upper Power Supply) to pin 4 of the Barrier Strip. Unplug the blue and brown wires from pins 2 and 4 of the Pump Relay (pins 4 and 8 of alternate Pump Relay). These are the wires that go to the Pump. Plug the machine into the wall outlet and turn the power ON. Does it trip the circuit breaker?
- Yes – Go to step 5.11
No – Change the Pump
- 5.11 With the machine unplugged from the wall outlet replace the blue and brown wires from the Pump to pins 2 and 4 of the Pump Relay (pins 4 and 8 of alternate Pump Relay). Unplug the blue and brown wires from pins 1 and 3 of the Pump Relay (pins 2 and 6 of alternate Pump Relay). These are the wires that come from the Barrier Strip. Plug the machine into the wall outlet and turn the power ON. Does it trip the circuit breaker?
- Yes – Change the Power Cord
No – Change the Pump Relay

- 5.12 With power ON, locate connector DBJ4, measure the voltage between pins 6 and 8 (black and yellow wires). Is there 24 VDC?



NOTE: YOU MAY HAVE TO START THE MODE YOU ARE HAVING PROBLEMS WITH TO SEE THE 24VDC DROP OUT.

- Yes – There is no 24 VDC problem indicated
 No – Go to step 5.13

- 5.13 Turn power OFF, unplug connectors DBJ2 and DBJ3 (pull straight down) from Control Board, turn the power ON, locate connector DBJ4, measure the voltage between pins 6 and 8 (black and yellow wires). Is there 24VDC?



NOTE: YOU MAY HAVE TO START THE MODE YOU ARE HAVING PROBLEMS WITH TO SEE THE 24VDC DROP OUT.

- Yes – Go to step 5.14
 No – Turn power OFF, reconnect the DBJ2 and DBJ3 connectors and go to step 5.15

- 5.14 Turn power OFF; reconnect DBJ2 and DBJ3 to the Control Board. The 24VDC is being pulled down by a hydraulic component when the connectors DBJ2 and DBJ3 are plugged in. To determine which hydraulic component is pulling down the 24VDC they must be isolated. Disconnect the components on either of those two connectors, one at a time, by disconnecting the wires from the connectors. Below is a list of the components with their connector pin outs.

Turn power OFF, one at a time, disconnect both wires for a component, turn the power back ON, locate connector DBJ4, measure the voltage between pins 6 and 8 (black and yellow wires) . If the 24VDC is there, replace the component you just isolated. If the 24VDC is not there, reconnect the wires from the component you just isolated and move on to the next component.



NOTE: YOU MAY HAVE TO START THE MODE YOU ARE HAVING PROBLEMS WITH TO SEE THE 24VDC DROP OUT.



NOTE: IF THE 24VDC DROPS OUT IN FILL MODE START BY ISOLATING THE JET VALVES.

DBJ2 Connector

Pins 1 and 2 (yellow wires)	Jet Valve
Pins 3 and 4 (orange wires)	Jet Valve
Pins 5 and 6 (violet and green wires)	Drain Valve Relay
Pins 7 and 8 (brown wires)	Fill Valve

DBJ3 Connector

Pins 1 and 2 (gray wires)	Pump Relay
Pins 3 and 4 (violet wires)	DIN Connector Assy.
Pins 5 and 6 (blue wires)	Transfer Valve
Pins 7 and 8 (green wires)	Recirc Valve

- 5.15 Turn the power OFF, remove Fuse 2 (fuse on right) from the Lower Power Supply and measure the resistance across the fuse. Is the fuse electrically open (OL on most meters) or closed (less than 0.5 ohms)?

- Open – Change the fuse
 Closed – Reinstall the fuse and go to step 5.16

5.16 Turn the power ON and measure between AC-1 and AC-2 (brown and blue wires) on the Upper Power Supply. Is there 120VAC?

Yes – Change the Upper Power Supply

No – Go to No Power troubleshooting step 5.1